

Approval body for construction products
and types of construction

Bautechnisches Prüfamt

An institution established by the Federal and
Laender Governments



European Technical Assessment

ETA-22/0726
of 30 January 2023

English translation prepared by DIBt - Original version in German language

General Part

Technical Assessment Body issuing the
European Technical Assessment:

Deutsches Institut für Bautechnik

Trade name of the construction product

SIKLA Wedge Anchor AN B / AN B fvz / AN B sh /
AN B A2 / AN B A4 / AN B HCR

Product family
to which the construction product belongs

Mechanical fastener for use in concrete

Manufacturer

Sikla Holding GmbH
Ägydiplatz 3
A-4600 THALHEIM BEI WELS
ÖSTERREICH

Manufacturing plant

Sikla Herstellwerk 1

This European Technical Assessment
contains

15 pages including 3 annexes which form an integral part
of this assessment

This European Technical Assessment is
issued in accordance with Regulation (EU)
No 305/2011, on the basis of

EAD 330232-01-0601, Edition 05/2021

The European Technical Assessment is issued by the Technical Assessment Body in its official language. Translations of this European Technical Assessment in other languages shall fully correspond to the original issued document and shall be identified as such.

Communication of this European Technical Assessment, including transmission by electronic means, shall be in full. However, partial reproduction may only be made with the written consent of the issuing Technical Assessment Body. Any partial reproduction shall be identified as such.

This European Technical Assessment may be withdrawn by the issuing Technical Assessment Body, in particular pursuant to information by the Commission in accordance with Article 25(3) of Regulation (EU) No 305/2011.

Specific Part

1 Technical description of the product

The SIKLA Wedge Anchor AN B / AN B fvz / AN B sh / AN B A2 / AN B A4 / AN B HCR is a fastener made of zinc coated steel or stainless steel which is placed into a drilled hole and anchored by application of the installation torque.

The product description is given in Annex A.

2 Specification of the intended use in accordance with the applicable European Assessment Document

The performances given in Section 3 are only valid if the fastener is used in compliance with the specifications and conditions given in Annex B.

The verifications and assessment methods on which this European Technical Assessment is based lead to the assumption of a working life of the fastener of at least 50 years. The indications given on the working life cannot be interpreted as a guarantee given by the producer, but are to be regarded only as a means for choosing the right products in relation to the expected economically reasonable working life of the works.

3 Performance of the product and references to the methods used for its assessment

3.1 Mechanical resistance and stability (BWR 1)

| Essential characteristic | Performance |
|--|-------------------------|
| Characteristic resistance to tension load (static and quasi static loading) Method A | See Annex B4, C1 and C2 |
| Characteristic resistance to shear load (static and quasi static loading) | See Annex C3 |
| Displacements | See Annex C4 |
| Characteristic resistance and displacements for seismic performance categories C1 and C2 | No performance assessed |

3.2 Safety in case of fire (BWR 2)

| Essential characteristic | Performance |
|--------------------------|-------------------------|
| Reaction to fire | Class A1 |
| Resistance to fire | No performance assessed |

3.3 Aspects of durability

| Essential characteristic | Performance |
|--------------------------|--------------|
| Durability | See Annex B1 |

4 Assessment and verification of constancy of performance (AVCP) system applied, with reference to its legal base

In accordance with the European Assessment Document EAD 330232-01-0601 the applicable European legal act is: [96/582/EC].

The system to be applied is: 1

5 Technical details necessary for the implementation of the AVCP system, as provided for in the applicable European Assessment Document

Technical details necessary for the implementation of the AVCP system are laid down in the control plan deposited with Deutsches Institut für Bautechnik.

Issued in Berlin on 30 January 2023 by Deutsches Institut für Bautechnik

Dipl.-Ing. Beatrix Wittstock
Head of Section

beglaubigt:
Baderschneider

SIKLA Wedge Anchor AN B / AN B fvz / AN B sh / AN B A2 / AN B A4 / AN B HCR

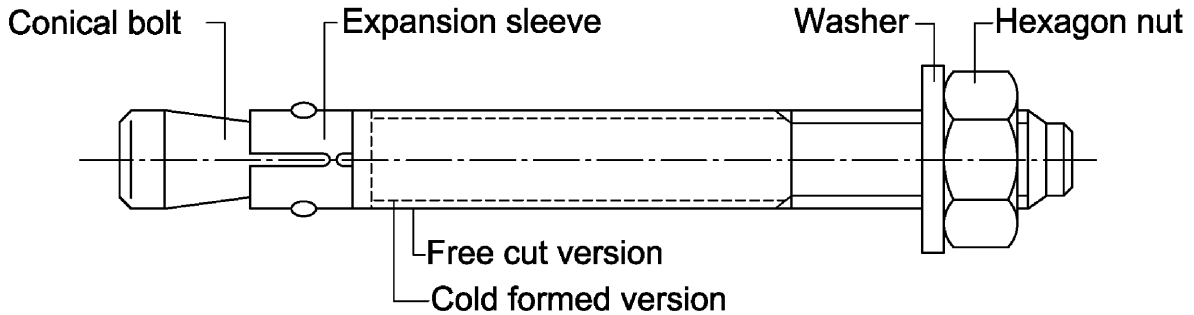

Table A1: Dimensions

| Anchor size | Anchor length L | | | Wrench size |
|-------------|--|--|--|-------------|
| | Embedment depth $h_{ef,1}$ | Embedment depth $h_{ef,2}$ | Embedment depth $h_{ef,3}$ | |
| M6 | $t_{fix, hef,1} + 47,4$ | $t_{fix, hef,2} + 57,4$ | $t_{fix, hef,3} + 77,4$ | 10 |
| M8 | $t_{fix, hef,1} + 57,4$ | $t_{fix, hef,2} + 66,4$ | $t_{fix, hef,3} + 92,4$ | 13 |
| M10 | $t_{fix, hef,1} + 68,0$ | $t_{fix, hef,2} + 74,0$ | $t_{fix, hef,3} + 106,0$ | 17 |
| M12 | $t_{fix, hef,1} + 82,3$ | $t_{fix, hef,2} + 97,3$ | $t_{fix, hef,3} + 132,3$ | 19 |
| M16 | $t_{fix, hef,1} + 103,0$ ($t_{fix, hef,1} + 101,8$) ¹⁾ | $t_{fix, hef,2} + 121,0$ ($t_{fix, hef,2} + 117,8$) ¹⁾ | $t_{fix, hef,3} + 159,0$ ($t_{fix, hef,3} + 157,8$) ¹⁾ | 24 |
| M20 | $t_{fix, hef,1} + 120,7$ | $t_{fix, hef,2} + 142,7$ | $t_{fix, hef,3} + 157,7$ | 30 |

¹⁾ Anchor version AN B A2 / AN B A4 / AN B HCR

Marking: e.g.: $\diamond 15/21$

- \diamond Identifying mark of manufacturing plant
- 15 maximum thickness of fixture for $h_{ef,2}$
- 21 maximum thickness of fixture for $h_{ef,1}$

additional marking:

- A2 stainless steel
- A4 stainless steel
- HCR high corrosion resistant steel

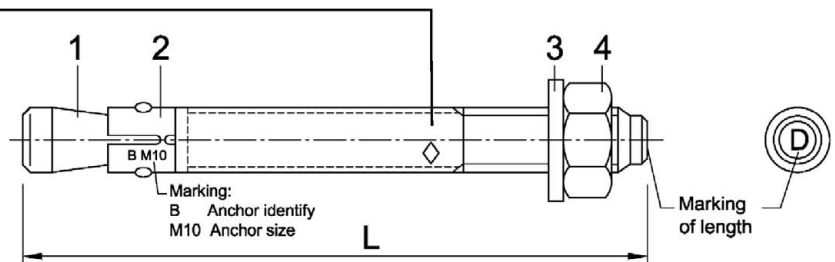

| Marking of length | A | B | C | D | E | F | G | H | I | J | K | L | M |
|-----------------------------|------|------|------|------|-------|-------|-------|-------|-------|-------|-------|-------|-------|
| Length of anchor min \geq | 38,1 | 50,8 | 63,5 | 76,2 | 88,9 | 101,6 | 114,3 | 127,0 | 139,7 | 152,4 | 165,1 | 177,8 | 190,5 |
| Length of anchor max $<$ | 50,8 | 63,5 | 76,2 | 88,9 | 101,6 | 114,3 | 127,0 | 139,7 | 152,4 | 165,1 | 177,8 | 190,5 | 203,2 |

| Marking of length | N | O | P | Q | R | S | T | U | V | W | X | Y | Z |
|-----------------------------|-------|-------|-------|-------|-------|-------|-------|-------|-------|-------|-------|-------|-------|
| Length of anchor min \geq | 203,2 | 215,9 | 228,6 | 241,3 | 254,0 | 279,4 | 304,8 | 330,2 | 355,6 | 381,0 | 406,4 | 431,8 | 457,2 |
| Length of anchor max $<$ | 215,9 | 228,6 | 241,3 | 254,0 | 279,4 | 304,8 | 330,2 | 355,6 | 381,0 | 406,4 | 431,8 | 457,2 | 483,0 |

Dimensions in mm

SIKLA Wedge Anchor AN B / AN B fvz / AN B sh / AN B A2 / AN B A4 / AN B HCR

Product description
Marking and Dimensions

Annex A1

Table A2: Materials

| Part | Designation | Material |
|--|--------------------|--------------------------------|
| Zinc plated steel | | |
| AN B | electroplated | ≥ 5 µm |
| AN B fvz | hot-dip galvanized | ≥ 50 µm |
| AN B sh | sherardized | ≥ 45 µm |
| 1 | Conical bolt | Cold formed or machined steel |
| 2 | Expansion sleeve | Stainless steel |
| 3 | Washer | Steel, zinc plated |
| 4 | Hexagon nut | Steel, zinc plated |
| Stainless steel | | |
| AN B A2 stainless steel CRC II ¹⁾ | | |
| 1 | Conical bolt | Stainless steel |
| 2 | Expansion sleeve | Stainless steel |
| 3 | Washer | Stainless steel |
| 4 | Hexagon nut | Stainless steel |
| AN B A4 stainless steel CRC III ¹⁾ | | |
| 1 | Conical bolt | Stainless steel |
| 2 | Expansion sleeve | Stainless steel |
| 3 | Washer | Stainless steel |
| 4 | Hexagon nut | Stainless steel |
| AN B HCR High corrosion resistant steel CRC V ¹⁾ | | |
| 1 | Conical bolt | High corrosion resistant steel |
| 2 | Expansion sleeve | Stainless steel |
| 3 | Washer | High corrosion resistant steel |
| 4 | Hexagon nut | High corrosion resistant steel |

¹⁾ Corrosion resistance class according to EN 1993-1-4:2015, Annex A, Table A.3

| | |
|--|-----------------|
| SIKLA Wedge Anchor AN B / AN B fvz / AN B sh / AN B A2 / AN B A4 / AN B HCR | Annex A2 |
| Product description Materials | |

Specifications of intended use

| AN B / AN B fvz / AN B sh / AN B A2 / AN B A4 / AN B HCR | | M6 | M8 | M10 | M12 | M16 | M20 |
|--|-------------------------------|-----------------|----|-----|-----|-----|-----|
| zinc plated steel | AN B (electroplated) | ✓ | ✓ | ✓ | ✓ | ✓ | ✓ |
| | AN B fvz (hot-dip galvanized) | - ¹⁾ | ✓ | ✓ | ✓ | ✓ | ✓ |
| | AN B sh (sherardized) | ✓ | ✓ | ✓ | ✓ | ✓ | ✓ |
| stainless steel | AN B A2 | ✓ | ✓ | ✓ | ✓ | ✓ | ✓ |
| | AN B A4 | ✓ | ✓ | ✓ | ✓ | ✓ | ✓ |
| | AN B HCR | ✓ | ✓ | ✓ | ✓ | ✓ | ✓ |
| all versions | static or quasi-static action | ✓ | | | | | |
| | uncracked concrete | ✓ | | | | | |

¹⁾ No Performance assessed

Base materials:

- Reinforced or unreinforced normal weight concrete without fibres according to EN 206:2013 + A1:2016
- Strength classes C20/25 to C50/60 according to EN 206:2013 + A1:2016

Use conditions (Environmental conditions):

- Structures subject to dry internal conditions (all materials)
- For all other conditions:

| Anchor version | Use according to EN 1993-1-4:2015 corresponding to the corrosion resistance class CRC according to Annex A, Table A2 |
|----------------|--|
| AN B A2 | CRC II |
| AN B A4 | CRC III |
| AN B HCR | CRC V |

Design:

- Anchorages are designed under the responsibility of an engineer experienced in anchorages and concrete work.
- Verifiable calculation notes and drawings are prepared taking account of the loads to be anchored. The position of the anchor is indicated on the design drawings (e.g. position of the anchor relative to reinforcement or to supports, etc.).
- Anchorages are designed according to EN 1992-4:2018 or TR 055:2018.

Installation:

- Hole drilling by hammer drill bit or vacuum drill bit.
- Use of the fastener only as supplied by the manufacturer without exchanging the components of the fastener.

| | |
|---|----------|
| SIKLA Wedge Anchor AN B / AN B fvz / AN B sh / AN B A2 / AN B A4 / AN B HCR | Annex B1 |
| Intended use Specifications | |

Installation parameters

Effective embedment depths $h_{ef,1}$

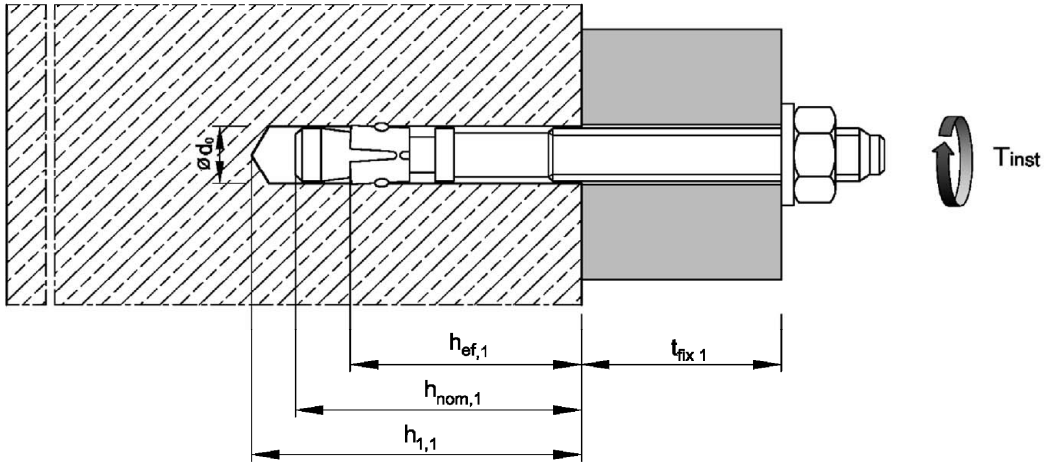

Effective embedment depths $h_{ef,2}$

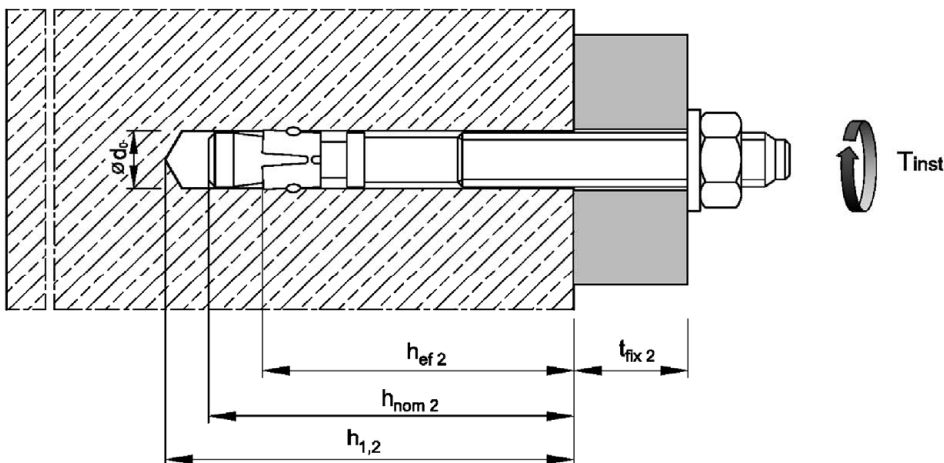

Effective embedment depths $h_{ef,3}$

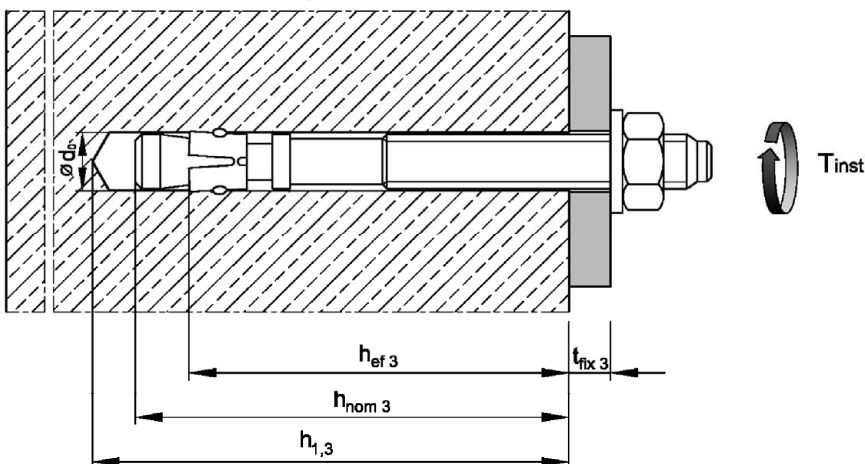

SIKLA Wedge Anchor AN B / AN B fvz / AN B sh / AN B A2 / AN B A4 / AN B HCR

Intended use
Specifications

Annex B2

Table B1: Installation parameters

| Anchor size | | | M6 | M8 | M10 | M12 | M16 | M20 | |
|--|------------------------------|--------------|------|------|-------|------|-----------------------|-------|-----|
| Nominal drill hole diameter | $d_0 =$ | [mm] | 6 | 8 | 10 | 12 | 16 | 20 | |
| Cutting diameter of drill bit | $d_{cut} \leq$ | [mm] | 6,40 | 8,45 | 10,45 | 12,5 | 16,5 | 20,55 | |
| Installation torque | AN B | $T_{inst} =$ | [Nm] | 8 | 15 | 30 | 50 | 100 | 200 |
| | AN B fvz | $T_{inst} =$ | [Nm] | -2) | 15 | 30 | 40 | 90 | 120 |
| | AN B sh | $T_{inst} =$ | [Nm] | 5 | 15 | 30 | 40 | 90 | 120 |
| | AN B A2 / AN B A4 / AN B HCR | $T_{inst} =$ | [Nm] | 6 | 15 | 25 | 50 | 100 | 160 |
| Diameter of clearance hole in the fixture | $d_f \leq$ | [mm] | 7 | 9 | 12 | 14 | 18 | 22 | |
| Embedment depth $h_{ef,1}$ | | | | | | | | | |
| Effective embedment depth | $h_{ef,1} \geq$ | [mm] | 30 | 35 | 42 | 50 | 64 | 78 | |
| Depth of drill hole | $h_{1,1} \geq$ | [mm] | 45 | 55 | 65 | 75 | 95 | 110 | |
| Embedment depth | $h_{nom,1} \geq$ | [mm] | 39 | 47 | 56 | 67 | 84 | 99 | |
| Embedment depth $h_{ef,2}$ | | | | | | | | | |
| Effective embedment depth | $h_{ef,2} \geq$ | [mm] | 40 | 44 | 48 | 65 | 82 (80) ¹⁾ | 100 | |
| Depth of drill hole | $h_{1,2} \geq$ | [mm] | 55 | 65 | 70 | 90 | 110 | 130 | |
| Embedment depth | $h_{nom,2} \geq$ | [mm] | 49 | 56 | 62 | 82 | 102 | 121 | |
| Embedment depth $h_{ef,3}$ | | | | | | | | | |
| Effective embedment depth | $h_{ef,3} \geq$ | [mm] | 60 | 70 | 80 | 100 | 120 | 115 | |
| Depth of drill hole | $h_{1,3} \geq$ | [mm] | 75 | 91 | 102 | 125 | 148 | 145 | |
| Embedment depth | $h_{nom,3} \geq$ | [mm] | 69 | 82 | 94 | 117 | 140 | 136 | |

¹⁾ Anchor version AN B A2 / AN B A4 / AN B HCR

²⁾ No Performance assessed

| | |
|--|-----------------|
| SIKLA Wedge Anchor AN B / AN B fvz / AN B sh / AN B A2 / AN B A4 / AN B HCR | Annex B3 |
| Intended use Installation parameters | |

3) **Minimum spacings and edge distances, zinc plated steel** ¹⁾

| Anchor size | | | M6 | M8 | M10 | M12 | M16 | M20 |
|--|-----------|------|-----|-----|-----|-----|-----|-----|
| Embedment depth $h_{ef,1}$ | | | | | | | | |
| Minimum member thickness | h_{min} | [mm] | 80 | 80 | 100 | 100 | 130 | 160 |
| Minimum spacing | s_{min} | [mm] | 35 | 40 | 55 | 100 | 100 | 140 |
| Minimum edge distance | c_{min} | [mm] | 40 | 45 | 65 | 100 | 100 | 140 |
| Embedment depth $h_{ef,2}$ | | | | | | | | |
| Minimum member thickness | h_{min} | [mm] | 100 | 100 | 100 | 130 | 170 | 200 |
| Minimum spacing | s_{min} | [mm] | 35 | 40 | 55 | 75 | 90 | 105 |
| Minimum edge distance | c_{min} | [mm] | 40 | 45 | 65 | 90 | 105 | 125 |
| Embedment depth $h_{ef,3}$ | | | | | | | | |
| Minimum member thickness | h_{min} | [mm] | 120 | 126 | 132 | 165 | 208 | 215 |
| Minimum spacing | s_{min} | [mm] | 35 | 40 | 55 | 75 | 90 | 105 |
| Minimum edge distance | c_{min} | [mm] | 40 | 45 | 65 | 90 | 105 | 125 |

¹⁾ Anchor version AN B fvz: M8-M20

4) **Minimum spacings and edge distances, stainless steel**

| Anchor size | | | M6 | M8 | M10 | M12 | M16 | M20 |
|--|--------------|------|-----|-----|-----|-----|-----|-----|
| Embedment depth $h_{ef,1}$ | | | | | | | | |
| Minimum member thickness | h_{min} | [mm] | 80 | 80 | 100 | 100 | 130 | 160 |
| Minimum spacing | s_{min} | [mm] | 35 | 60 | 55 | 100 | 110 | 140 |
| Minimum edge distance | c_{min} | [mm] | 40 | 60 | 65 | 100 | 110 | 140 |
| Embedment depth $h_{ef,2}$ | | | | | | | | |
| Minimum member thickness | h_{min} | [mm] | 100 | 100 | 100 | 130 | 160 | 200 |
| Minimum spacing | s_{min} | [mm] | 35 | 35 | 45 | 60 | 80 | 100 |
| | for $c \geq$ | [mm] | 40 | 65 | 70 | 100 | 120 | 150 |
| Minimum edge distance | c_{min} | [mm] | 35 | 45 | 55 | 70 | 80 | 100 |
| | for $s \geq$ | [mm] | 60 | 110 | 80 | 100 | 140 | 180 |
| Embedment depth $h_{ef,3}$ | | | | | | | | |
| Minimum member thickness | h_{min} | [mm] | 120 | 126 | 132 | 165 | 200 | 215 |
| Minimum spacing | s_{min} | [mm] | 35 | 35 | 45 | 60 | 80 | 100 |
| | for $c \geq$ | [mm] | 40 | 65 | 70 | 100 | 120 | 150 |
| Minimum edge distance | c_{min} | [mm] | 35 | 45 | 55 | 70 | 80 | 100 |
| | for $s \geq$ | [mm] | 60 | 110 | 80 | 100 | 140 | 180 |

Intermediate values by linear interpolation.

SIKLA Wedge Anchor AN B / AN B fvz / AN B sh / AN B A2 / AN B A4 / AN B HCR

Intended use
Minimum spacings and edge distances

Annex B4

Installation instructions

| | | |
|---|--|--|
| 1 | | <p>Drill hole perpendicular to concrete surface. If using a vacuum drill bit, proceed with step 3.</p> |
| 2 | | <p>Blow out dust. Alternatively, vacuum clean down to the bottom of the hole.</p> |
| 3 | | <p>Drive in anchor, such that the selected embedment depth is met.</p> |
| 4 | | <p>Apply installation torque T_{inst} as specified in Table B1.</p> |

SIKLA Wedge Anchor AN B / AN B fvz / AN B sh / AN B A2 / AN B A4 / AN B HCR

Intended use
Installation instructions

Annex B5

Table C1: Characteristic values for tension loads, zinc plated steel ¹⁾

| Anchor size | | | M6 | M8 | M10 | M12 | M16 | M20 | |
|--|--------------------|-------------|---|-------------------------|--------------------|------|---|--|------|
| Installation factor | γ_{inst} | [-] | 1,0 | | | | | | |
| Steel failure | | | | | | | | | |
| Characteristic resistance | $N_{Rk,s}$ | [kN] | 8,7 | 15,3 | 26 | 35 | 65 | 107 | |
| Partial factor ⁴⁾ | γ_{Ms} | [-] | 1,5 | | | | 1,6 | | |
| Pull-out | | | | | | | | | |
| Characteristic resistance in uncracked concrete C20/25 | for $h_{ef,1}$ | $N_{Rk,p}$ | [kN] | 6,5 ²⁾ | 10,2 ²⁾ | 13,4 | 17,4 | 25,2 | 33,9 |
| | for $h_{ef,2}$ | $N_{Rk,p}$ | [kN] | 10 | 13 | 16,4 | 25,8 | 36,5 | 49,2 |
| | for $h_{ef,3}$ | $N_{Rk,p}$ | [kN] | 10 | 13 | 16,4 | 26 | 40 | 55 |
| Increasing factor $N_{Rk,p} = \psi_C \cdot N_{Rk,p} (C20/25)$ | ψ_C | [-] | $\left(\frac{f_{ck}}{20}\right)^{0,5}$ | | | | $\left(\frac{f_{ck}}{20}\right)^{0,33}$ | $\left(\frac{f_{ck}}{20}\right)^{0,5}$ | |
| Splitting | | | | | | | | | |
| Characteristic resistance | $N^0_{Rk,sp}$ | [kN] | min [$N_{Rk,p}$; $N^0_{Rk,c}$ ³⁾] | | | | | | |
| Embedment depth $h_{ef,1}$ | | | | | | | | | |
| Spacing | $s_{cr,sp}$ | [mm] | 180 | 210 | 230 | 240 | 320 | 400 | |
| Edge distance | $c_{cr,sp}$ | [mm] | 90 | 105 | 115 | 120 | 160 | 200 | |
| Embedment depth $h_{ef,2}$ | | | | | | | | | |
| Spacing | $s_{cr,sp}$ | [mm] | 160 | 220 | 240 | 330 | 410 | 500 | |
| Edge distance | $c_{cr,sp}$ | [mm] | 80 | 110 | 120 | 165 | 205 | 250 | |
| Embedment depth $h_{ef,3}$ | | | | | | | | | |
| Spacing | $s_{cr,sp}$ | [mm] | 160 | 220 | 240 | 330 | 410 | 520 | |
| Edge distance | $c_{cr,sp}$ | [mm] | 80 | 110 | 120 | 165 | 205 | 260 | |
| Concrete cone failure | | | | | | | | | |
| Effective embedment depth | for $h_{ef,1}$ | [mm] | 30 ²⁾ | 35 ²⁾ | 42 | 50 | 64 | 78 | |
| | for $h_{ef,2}$ | [mm] | 40 | 44 | 48 | 65 | 82 | 100 | |
| | for $h_{ef,3}$ | [mm] | 60 | 70 | 80 | 100 | 120 | 115 | |
| Spacing | $s_{cr,N}$ | [mm] | 3 $h_{ef(1,2,3)}$ | | | | | | |
| Edge distance | $c_{cr,N}$ | [mm] | 1,5 $h_{ef(1,2,3)}$ | | | | | | |
| Factor | uncracked concrete | $k_{ucr,N}$ | [-] | 11,0 | | | | | |
| | cracked concrete | $k_{cr,N}$ | [-] | No performance assessed | | | | | |

¹⁾ Anchor version AN B fvz: M8-M20

²⁾ Restricted to the use of structural components with $h_{ef} < 40$ mm which are statically indeterminate and subject to internal exposure conditions only

³⁾ $N^0_{Rk,c}$ according to EN 1992-4:2018

⁴⁾ In absence of other national regulations

SIKLA Wedge Anchor AN B / AN B fvz / AN B sh / AN B A2 / AN B A4 / AN B HCR

Performance
Characteristic values for **tension loads, zinc plated steel**

Annex C1

Table C2: Characteristic values for tension loads, stainless steel

| Anchor size | | | M6 | M8 | M10 | M12 | M16 | M20 | |
|---|--|---------------|--|--|-----------------|------|------|------|------|
| Installation factor | γ_{inst} | [-] | 1,0 | | | | | | |
| Steel failure | | | | | | | | | |
| Characteristic resistance | $N_{Rk,s}$ | [kN] | 10 | 18 | 30 | 44 | 88 | 134 | |
| Partial factor ³⁾ | γ_{Ms} | [-] | 1,50 | | | | | | |
| Pull-out | | | | | | | | | |
| Characteristic resistance in uncracked concrete C20/25 | for $h_{ef,1}$ | $N_{Rk,p}$ | [kN] | 6,5 ¹⁾ | 9 ¹⁾ | 12 | 17,4 | 25,2 | 33,9 |
| | for $h_{ef,2}$ | $N_{Rk,p}$ | [kN] | 8 | 15 | 16,4 | 25 | 35,2 | 49,2 |
| | for $h_{ef,3}$ | $N_{Rk,p}$ | [kN] | 8 | 15 | 16,4 | 25 | 42 | 60 |
| Increasing factor $N_{Rk,p} = \psi_C \cdot N_{Rk,p} (C20/25)$ | ψ_C | [-] | $\left(\frac{f_{ck}}{20}\right)^{0,5}$ | | | | | | |
| Splitting | | | | | | | | | |
| Characteristic resistance | $N^0_{Rk,sp}$ | [kN] | $\min [N_{Rk,p} ; N^0_{Rk,c}]$ | | | | | | |
| Embedment depth $h_{ef,1}$ | | | | | | | | | |
| Spacing | $s_{cr,sp}$ | [mm] | 180 | 210 | 230 | 300 | 320 | 400 | |
| Edge distance | $c_{cr,sp}$ | [mm] | 90 | 105 | 115 | 150 | 160 | 200 | |
| Embedment depth $h_{ef,2}$ | | | | | | | | | |
| The higher one of the decisive resistances of Case 1 and Case 2 is applicable | | | | | | | | | |
| Case 1 | Characteristic resistance | $N^0_{Rk,sp}$ | [kN] | 6 | 9 | 12 | 20 | 30 | 40 |
| | Spacing | $s_{cr,sp}$ | [mm] | 3 h_{ef} | | | | | |
| | Edge distance | $c_{cr,sp}$ | [mm] | 1,5 h_{ef} | | | | | |
| | Increasing factor $N^0_{Rk,sp} = \psi_C \cdot N^0_{Rk,sp} (C20/25)$ | ψ_C | [-] | $\left(\frac{f_{ck}}{20}\right)^{0,5}$ | | | | | |
| Case 2 | Spacing | $s_{cr,sp}$ | [mm] | 160 | 220 | 240 | 340 | 410 | 560 |
| | Edge distance | $c_{cr,sp}$ | [mm] | 80 | 110 | 120 | 170 | 205 | 280 |
| Embedment depth $h_{ef,3}$ | | | | | | | | | |
| Spacing | $s_{cr,sp}$ | [mm] | 160 | 220 | 240 | 340 | 410 | 620 | |
| Edge distance | $c_{cr,sp}$ | [mm] | 80 | 110 | 120 | 170 | 205 | 310 | |
| Concrete cone failure | | | | | | | | | |
| Effective embedment depth | for $h_{ef,1} \geq$ | [mm] | 30 ¹⁾ | 35 ¹⁾ | 42 | 50 | 64 | 78 | |
| | for $h_{ef,2} \geq$ | [mm] | 40 | 44 | 48 | 65 | 80 | 100 | |
| | for $h_{ef,3} \geq$ | [mm] | 60 | 70 | 80 | 100 | 120 | 115 | |
| Spacing | $s_{cr,N}$ | [mm] | 3 h_{ef} | | | | | | |
| Edge distance | $c_{cr,N}$ | [mm] | 1,5 h_{ef} | | | | | | |
| Factor | uncracked concrete | $k_{ucr,N}$ | [-] | 11,0 | | | | | |
| | cracked concrete | $k_{cr,N}$ | [-] | No performance assessed | | | | | |

¹⁾ Restricted to the use of structural components with $h_{ef} < 40$ mm which are statically indeterminate and subject to internal exposure conditions only

²⁾ $N^0_{Rk,c}$ according to EN 1992-4:2018

³⁾ In absence of other national regulations

SIKLA Wedge Anchor AN B / AN B fvz / AN B sh / AN B A2 / AN B A4 / AN B HCR

Performance
Characteristic values for **tension loads, stainless steel**

Annex C2

Table C3: Characteristic values for shear loads

| Anchor size | | | | M6 | M8 | M10 | M12 | M16 | M20 |
|--|---------------------------------|-----------------|------|------------------|------------------|-----|-----|--------------------------|-----|
| Installation factor | | γ_{inst} | [-] | 1,0 | | | | | |
| Steel failure without lever arm | | | | | | | | | |
| Characteristic resistance | zinc plated steel ¹⁾ | $V_{Rk,s}^0$ | [kN] | 5 | 11 | 17 | 25 | 44 | 69 |
| | stainless steel | $V_{Rk,s}^0$ | [kN] | 7 | 12 | 19 | 27 | 50 | 86 |
| Ductility factor | | k_7 | [-] | 1,0 | | | | | |
| Steel failure with lever arm | | | | | | | | | |
| Characteristic bending resistance | zinc plated steel ¹⁾ | $M_{Rk,s}^0$ | [Nm] | 9 | 23 | 45 | 78 | 186 | 363 |
| | stainless steel | $M_{Rk,s}^0$ | [Nm] | 10 | 24 | 49 | 85 | 199 | 454 |
| Partial factor ⁴⁾ for $V_{Rk,s}^0$ and $M_{Rk,s}^0$ | zinc plated steel ¹⁾ | γ_{Ms} | [-] | 1,25 | | | | 1,33 | |
| | stainless steel | γ_{Ms} | [-] | 1,25 | | | | 1,4 | |
| Concrete pry-out failure | | | | | | | | | |
| Factor for h_{ef} | zinc plated steel ¹⁾ | k_8 | [-] | 1,0 | 2,3 | 2,5 | 2,9 | 2,8 | 3,1 |
| | stainless steel | k_8 | [-] | 1,0 | 2,3 | 2,8 | 2,8 | 3,0 | 3,3 |
| Concrete edge failure | | | | | | | | | |
| Effective length of anchor in shear loading | for $h_{ef,1}$ | l_f | [mm] | 30 ²⁾ | 35 ²⁾ | 42 | 50 | 64 | 78 |
| | for $h_{ef,2}$ | l_f | [mm] | 40 | 44 | 48 | 65 | 82 (80) ³⁾ | 100 |
| | for $h_{ef,3}$ | l_f | [mm] | 60 | 70 | 80 | 100 | 120 | 115 |
| Outside diameter of anchor | | d_{nom} | [mm] | 6 | 8 | 10 | 12 | 16 | 20 |

¹⁾ Anchor version AN B fvz: M8-M20

²⁾ Restricted to the use of structural components which are statically indeterminate and subject to internal exposure conditions only

³⁾ Anchor version stainless steel

⁴⁾ In absence of other national regulations

SIKLA Wedge Anchor AN B / AN B fvz / AN B sh / AN B A2 / AN B A4 / AN B HCR

Performance
Characteristic values for **shear loads**

Annex C3

Table C4: Displacements under tension load

| Anchor size | | | M6 | M8 | M10 | M12 | M16 | M20 |
|--|--------------------|------|-----|-----|-----|------|------|------|
| Embedment depth $h_{ef,1}$ | | | | | | | | |
| zinc plated steel ¹⁾ | | | | | | | | |
| Tension load | N | [kN] | 2,9 | 5,0 | 6,5 | 8,5 | 12,3 | 16,6 |
| Displacement | δ_{N0} | [mm] | 0,3 | 0,4 | | | | |
| | $\delta_{N\infty}$ | [mm] | 0,6 | 1,8 | | | | |
| stainless steel | | | | | | | | |
| Tension load | N | [kN] | 2,9 | 4,3 | 5,7 | 8,5 | 12,3 | 16,6 |
| Displacement | δ_{N0} | [mm] | 0,4 | 0,7 | 0,4 | 0,4 | 0,6 | 1,5 |
| | $\delta_{N\infty}$ | [mm] | 1,3 | | | | | 2,9 |
| Embedment depth $h_{ef,2}$ and $h_{ef,3}$ | | | | | | | | |
| zinc plated steel ¹⁾ | | | | | | | | |
| Tension load | N | [kN] | 4,3 | 5,8 | 7,6 | 11,9 | 16,7 | 23,8 |
| Displacement | δ_{N0} | [mm] | 0,4 | 0,5 | | | | |
| | $\delta_{N\infty}$ | [mm] | 0,7 | 2,3 | | | | |
| stainless steel | | | | | | | | |
| Tension load | N | [kN] | 3,6 | 5,7 | 7,6 | 11,9 | 17,2 | 24,0 |
| Displacement | δ_{N0} | [mm] | 0,7 | 0,9 | 0,5 | 0,6 | 0,9 | 2,1 |
| | $\delta_{N\infty}$ | [mm] | 1,8 | | | | | 4,2 |

¹⁾ Anchor version AN B fvz: M8-M20

Table C5: Displacements under shear loads

| Anchor size | | | M6 | M8 | M10 | M12 | M16 | M20 |
|--|--------------------|------|-----|-----|------|------|------|------|
| zinc plated steel ¹⁾ | | | | | | | | |
| Shear load | V | [kN] | 2,9 | 6,3 | 9,7 | 14,3 | 23,6 | 37,0 |
| Displacement | δ_{V0} | [mm] | 1,2 | 1,5 | 1,6 | 2,6 | 3,1 | 4,4 |
| | $\delta_{V\infty}$ | [mm] | 2,4 | 2,2 | 2,4 | 3,9 | 4,6 | 6,6 |
| stainless steel | | | | | | | | |
| Shear load | V | [kN] | 4,0 | 6,9 | 10,9 | 15,4 | 28,6 | 43,7 |
| Displacement | δ_{V0} | [mm] | 1,1 | 2,0 | 1,2 | 2,0 | 2,2 | 2,1 |
| | $\delta_{V\infty}$ | [mm] | 1,7 | 3,0 | 1,8 | 3,0 | 3,3 | 3,2 |

¹⁾ Anchor version AN B fvz: M8-M20

SIKLA Wedge Anchor AN B / AN B fvz / AN B sh / AN B A2 / AN B A4 / AN B HCR

Performance
Displacements

Annex C4