

Siaqua Roof Drainage Installation Technology

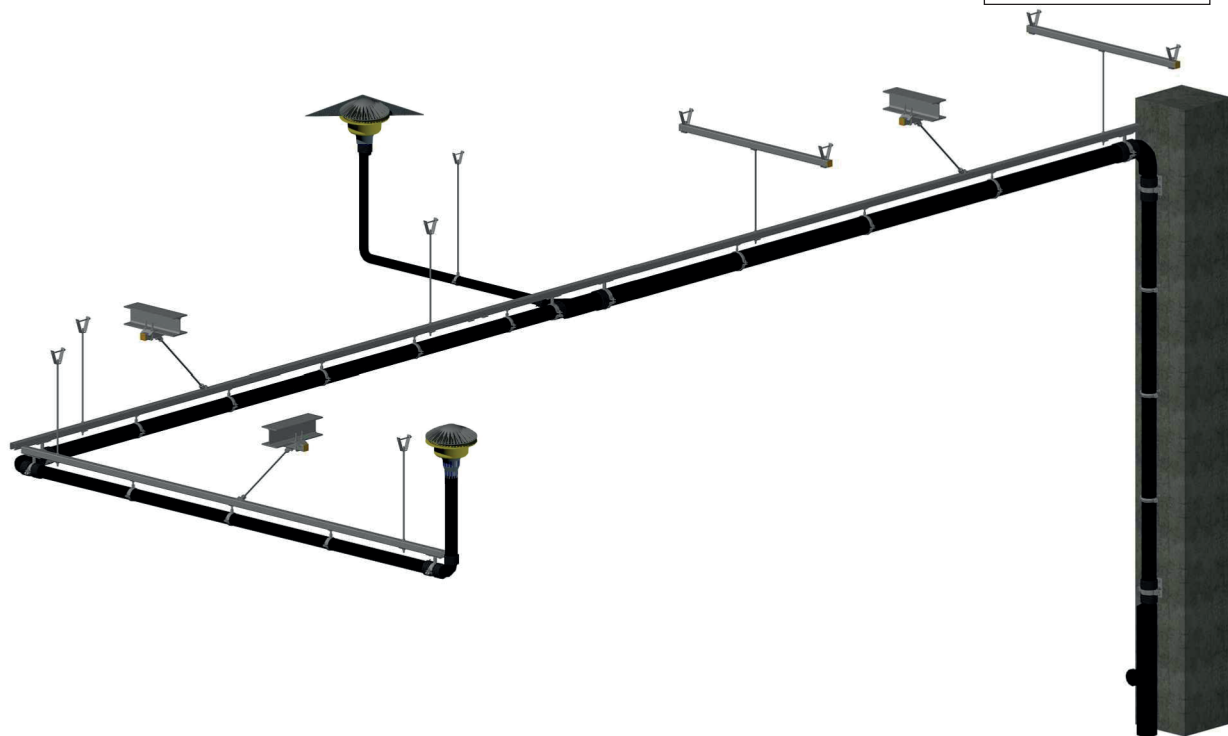

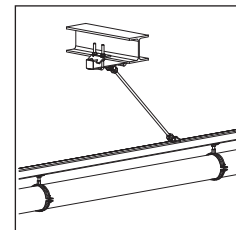
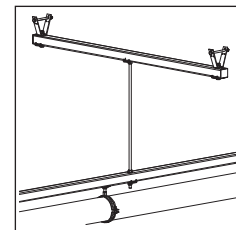
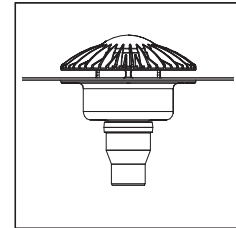

Sikla Drain GmbH
Erinstraße 14
44575 Castrop-Rauxel
Tel.: 02305 9778 0
Fax.: 02305 9778 13
Email: info@sikladrain.com
www.sikladrain.com

The current Sikla Drain purchase, delivery and payment terms and conditions apply. Sikla Drain does not assume any guarantee for the provided information being current, accurate and complete. The warranty shall be rendered void if the installation instructions are not carefully followed.

System description

In commercial- and industrial construction there normally is a flat roof. To ensure efficient functioning, a fast and save draining network is important. The planners have to choose between two different systems:

- Gravity drainage system
- Syphonic drainage system

The gravity drainage system drains the rainwater in partly filled pipes . The system is characterised by a large number of roof drains an down pipes. The rainwater is collected in drainage lines, which should be laid with a slope. The advantages are: simple dimensioning, unrestricted use for almost every roof shape and especially for small roof space.

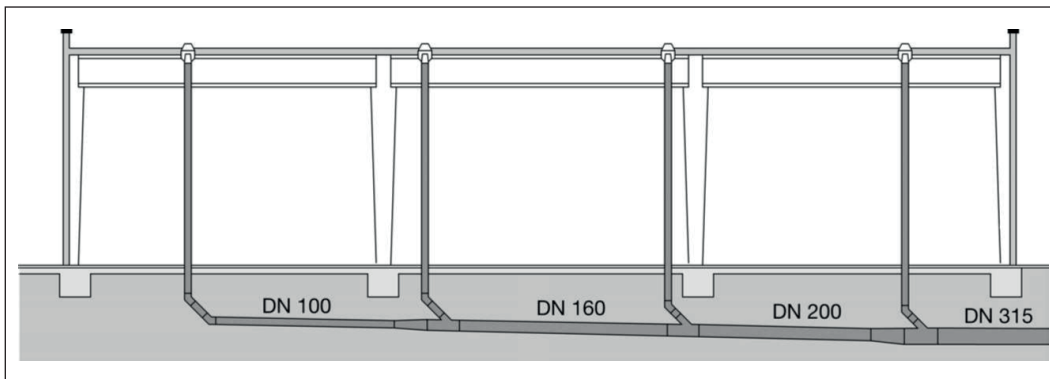

Gravity drainage system

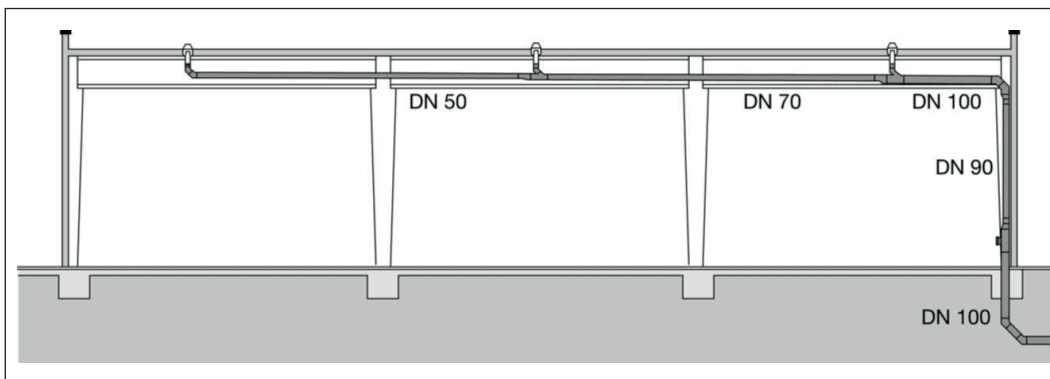

Siphonic drainage system

By contrast the syphonic drainage system drains the rainwater, by less but special roof drains, in collecting lines which are laid with no slope directly under the ceiling. A single down pipe drops the rainwater from the collecting pipe to the collecting shaft or an underground pipe.

Until dropping into the underground pipe the whole pipework is designed with full charge.

The calumn of water inside the fullfilled down pipe creates a vacuum in the collecting pipe and leads to a siphon effect which drains the roof. In order to size a syphonic drainage system a hydraulic balancing is needed. For modern, large roof space the system is characterised by the following advantages:

- Small amount of roof drains and less roof penetrations
- Minimum number of down- and underground pipes, less ground works
- Highest flow capacity on small pipe diameters
- Installation of the collecting line with no slope directly under the ceiling
- Self cleaning effect because of high flow velocities

System components

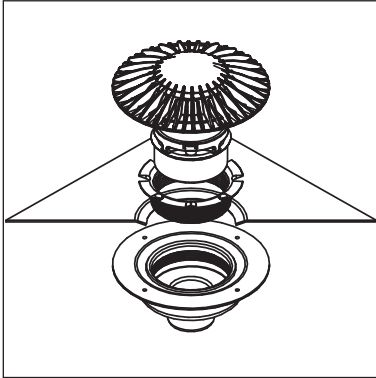

Roof drains for siphonic drainage systems

For siphonic roof drainage systems high performance roof drains from the materials PE, PUR, stainless steel and FPO-PP are available. 500 m² can be drained with these roof drains easily. The roof drains are easy to install and are adjustable for different roof structures thanks to a wide range of accessoires.

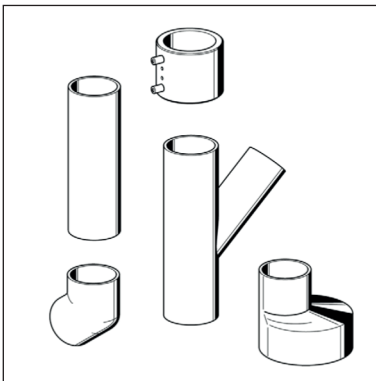

PE- HD pipe system

Absolutely sealed welded connections can be produced with the established PE-HD system. This is a guarantee for long term working drainage systems.

Pipe system PE- HDV - reinforced SDR 26

Complex pipeworks in siphonic drainage systems with dimension of 200 up to 315 and a max. vacuum of 800 mbar can be realised with the reinforced pipe system PE-HDV. At large surfaces the pipe diameters can be kept small. With the reinforced fittings like reducers, elbows and tees a complete reinforces pipe-work is possible.

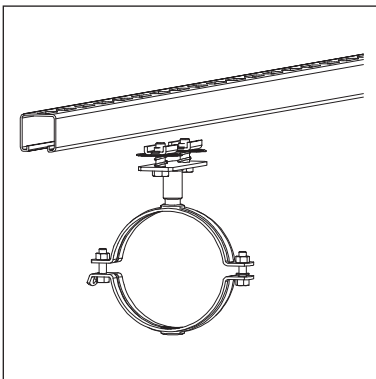

Fastening system

The newly developed Siaqua fastening system is based on a fixed installation. Because of the high level of prefabrication of the clamp adaptations and primary use of standard Siconnect elements a fast, easy and cost-optimised assembly is possible.

The Siaqua fastening system is available in two different types:

- with sound insulation by EPDM inlays in the pipe clamps (w.in.)
- without sound insulation in the pipe clamps (w/o.in.)

The Siaqua fastening system can be combined perfectly with Siconnect components. So fastening solution can be realised on every building structure.

Siaqua- Services

We will be happy to help planning and executing your draining projects.

- personal consultation
- technical elaboration
- tender specification
- offer preparation
- logistics and operations
- on-site assistance

Planning foundation

Siaqua- roof drain

Calculation rainwater discharge

For calculating rainwater discharge
Following factors are important:

- Rainfall r [l/s*ha]
- Surface exposed to rain A [m²]
- Discharge coefficient c

$$Q = r \cdot A \cdot c$$

Rainfall r [l/s*ha]

The design rainfall intensity $r_{(D,T)}$ is within the scope of DIN 1986-100 a rainfall event [l/s*ha] defined by rainfall duration D and annuality.

These rainfall events can be requested from public authorities or local weather services.

Surfaces exposed to rain A [m²]

The horizontal projection of the roof space is used for calculation.

Discharge coefficient c

The discharge coefficient c takes account of the slope and the water absorbency of the roof to be drained.
According to DIN 1986-100 following values apply:

- $c = 1,0$ for foil roofs, sheet metal roofs, roofs with tiles, sealed concrete surfaces, pavement with sealing compound
- $c = 0,5^*$ for gravel roofs and green roofs with extensive roof plantings with a structural height up to 10cm.
- $c = 0,3^*$ for green roofs with extensive roof plantings with a structural height from 10cm and for green roofs with intensive roof plantings.

- * With special materials permeable or retaining to water the discharge coefficient determined by the producer shall be Considered.

Emergency roof drains

Emergency roof drains should minimize the risk of rain water leaking inside the building or prevent damage to the building structure due to overload

According to DIN 1986-100 every roof area, regardless of size, has to have at least two same sized roof drains or one roof drain and another emergency roof drain.

Siaqua siphonic roof drainage

Calculating the number of roof drains

The rainwater discharge of a roof space is divided with the maximum discharge capacity, respectively the rated output of the roof drain V_{max} . Odd results are to be rounded to the next big number

Siphonic roof drainage systems are hydraulically balanced, that's why the planning should include a reserve of 10% off the discharge capacity. Even the minimal discharge capacity per roof drain V_{min} should be noticed, or else a complete filling of the pipe system can't be reached during rainfall events.

The discharge capacity is determined by the size of the connection pipe of the roof drain. (See table 1)

Table 1: Discharge capacity of Siaqua roof drains

Roof drain	Connection pipe size	V_{max} [l/s]
PE roof drain	70/75	17,4
PUR roof drain	90/90	15,6
FPO-PP roof drain	70/75	17,4
Stainless steel roof drain	70/75	16,4

Beside the discharge capacity, the distance between roof drains, the static boundary conditions and the emergency drainage concept are important.

Dimensioning of the collecting pipe (connection pipe) and the down pipe

Both pipelinesections, including the connections to the roof drains, are hydraulically balanced as a fixed system. Therefore a special developed Software is used. The technical guideline VDI 3806 serves as the basis for calculation.

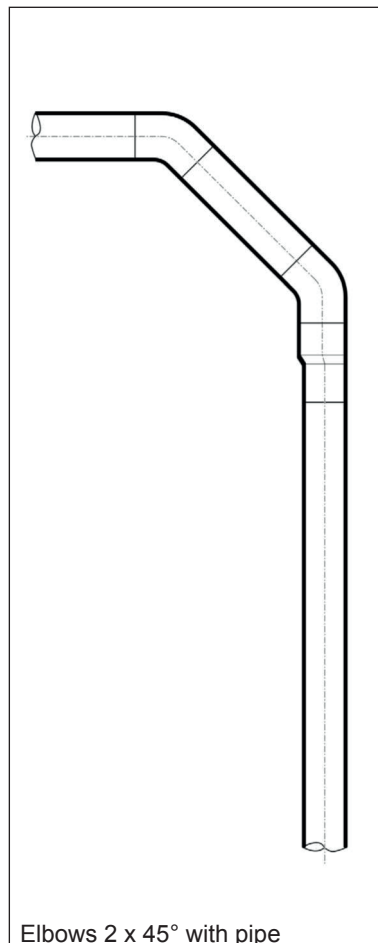
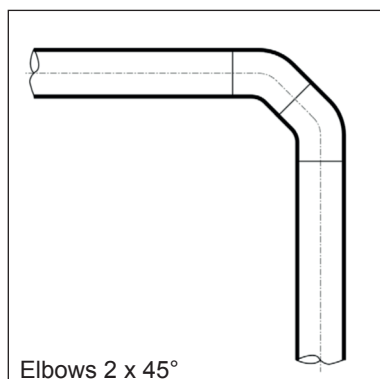
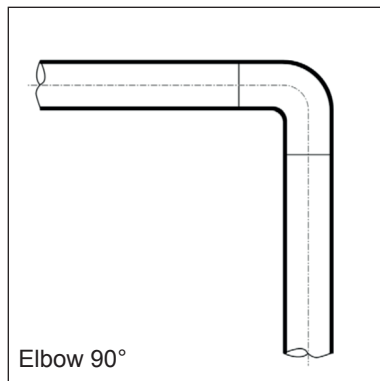

To ensure the functionality during rainfall events the starting behaviour of the Siaqua system is verified by calculation. A particularly important role during calculation is given to the transitions from the horizontal collecting pipe to the vertical down pipe. Even a reducing of the pipe diameter in flow direction can be necessary for the hydraulic balance.

For possible solutions see the pictures on the left.

Pipe routing

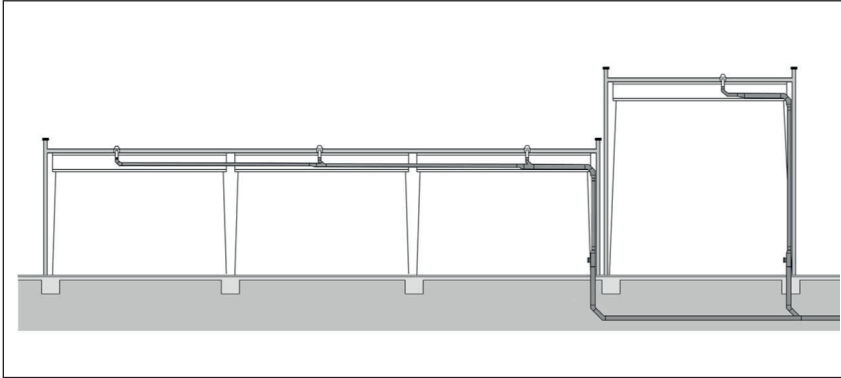

When planning the pipework make sure all roof drains connected to the down pipe are on the same level.

Roofs with different discharge coefficients have to be drained with separate pipe works.

Slopes and dimensions

The collection pipe may be installed without a slope. The smallest permissible nominal diameter is 32mm in siphonic drainage systems.

Reducing the nominal diameter of pipes in water flow direction is permissible, but should be done in vertical pipelines only.

Flow velocity

To keep the self cleaning effect alive, the flow velocity should always be above 5m/s. Übliche Strömungsgeschwindigkeiten liegen bei ca. 2 bis 5 m/s. The usual flow velocities are between 2 and 5 m/s.

In transition from siphonic- to gravity drainage systems, the high kinetic energy by the flow pressure should be considered.

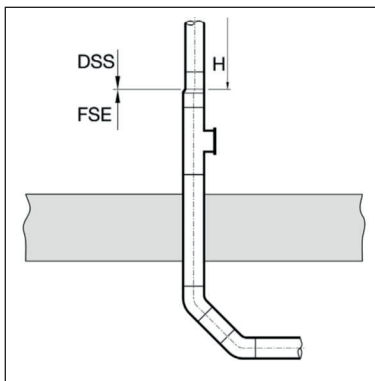

Transition to gravity drainage system

The interface between siphonic- and gravity drainage systems must be observed exactly, to ensure that the column of water in the down pipe stays at its planned size. If not, the siphonic drainage system will not work flawlessly. After the interface the pipe-work should be installed according to DIN 1986-100. The length of the down pipe (H) should be at least the height of a storey of the building.

Vacuum

The maximum permissible vacuum in siphonic roof drainage systems is:

- 800 mbar from de 40 up to de 160 mm PE-HD drain pipe
- 450 mbar from de 200 up to de 315 mm PE-HD drain pipe
- 800 mbar from de 200 up to de 315 mm PE-HDV drain pipe reinforced SDR 26

If complex siphonic drainage systems with the dimensions 200 up to 315 are planned and installed, reinforced Siqua fittings should be used.

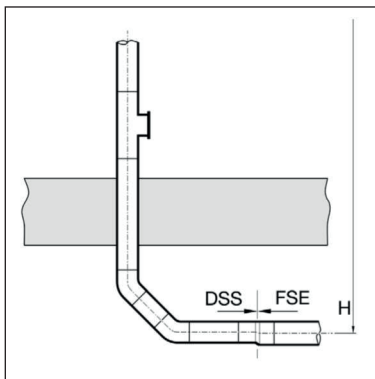

Standards, certificates and warranty

Standards

The state of art for siphonic roof drainage systems and the needed components (roof drains, PE-HD pipe work) is explained in following standards and norms:

- DIN EN 1253 Gullies for buildings Part 1-5
- DIN EN 1519 Plastics piping systems for soil and waste discharge (low and high temperature) within the building structure - Polyethylene (PE) Part 1
- DIN EN 12056 Gravity drainage systems inside building Part 1-5
- DIN 1986 Drainage systems on private grounds
- VDI 3806 Roof drainage with siphonic system

Certificates

We will be happy to make valid certificates for Siaqua systems available to you

Warranty

The Sikla warranty only applies if the Siaqua system is installed the way calculations and installation guidelines are Observed. There is no warranty for expert execution.

Contents

I Geberal

How to use the installation instructions	page 10
Recommended order of installation	page 10

II Pipework Diagram an Installation Drawings

Pipework diagram	page 11
Complete installation	page 12
Siaqua fixing material of supporting rail	page 14
Siaqua PE-HD material	page 16
Siaqua structural fixtures	page 18
Siaqua fire protection	page 20

III Assemblies an Installation Guidelines

Siaqua roof drains and accessories	(Pos 1)	page 27
Siaqua fastening material: supporting rail	(Pos 2)	page 37
Siaqua PE-HD material	(Pos 3)	page 43
Siaqua structural fixtures	(Pos 4)	page 59
Siaqua fire protections	(Pos 5)	page 78

IV Examples

Installation examples	page 81
Pipework diagram- installation	page 84

V Attachments

Notes	page 87
Purchase, delivery and payment terms and conditions	page 88

List of tables:

Table 1:	Fastening distances permissible for the Siaqua supporting rail	page 38 / 62
Table 2:	Fastening distances permissible for the Siaqua standard fixtures	page 40
Table 3:	Heated- tool butt welding specifications	page 48
Table 4:	Insertion depth of long sockets	page 51
Table 5:	Fastening distances permissible for the Siaqua single joint	page 60
Table 6:	Fastening distances permissible on trapezoidal sheet metal	page 62
Table 7:	Fastening distances permissible on steel beam joint	page 67
Table 8:	Fastening distances permissible for the Siaqua down pipe joint	page 71

How to use the installation instructions

These installation instructions are designed to help install Siaqua roof drainage systems according to the pipework diagrams for your specific project. They are divided into the following sections:

- I General
- II Pipework diagram an installation drawings
- III Assemblies and Installation Guidelines
- IV Examples

The pipework diagrams for the Siaqua roof drainage systems are provided by Sikla Drain GmbH. An example of a pipework diagram is illustrated in section II (page 5) and explained in detail using another diagram. The installation drawings show how the roof drainage system can be installed for a particular pipework diagram. Each installation drawing depicts a different aspect of the drainage system and are arranged in the following order:

- Siaqua fastening material: supporting rail (pos. 2)
- Siaqua HDPE material (pos. 3)
- Siaqua structural fixtures (pos. 4)
- Siaqua fire protection (pos. 5)

Recommended order of installation

- First install the structural fixtures including the supporting rail
- Then install the Siaqua standard fixtures in accordance with table 2 (page 40)
- Loosely assemble the Siaqua fixed points to allow horizontal adjustment if necessary
- Insert the pipework into the pipe clip. Loosely tighten the two halves of the pipe clip
- Weld the pipes and fittings together without applying any tension
- Securely tighten the fixtures and the two halves of the pipe clip together without deforming the pipework

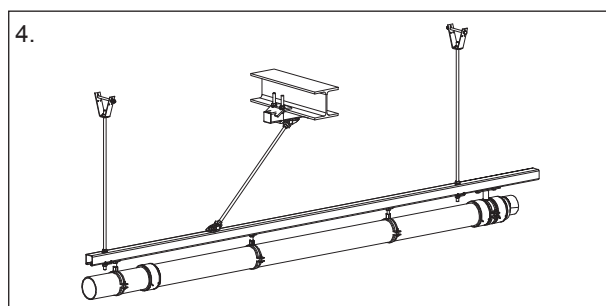
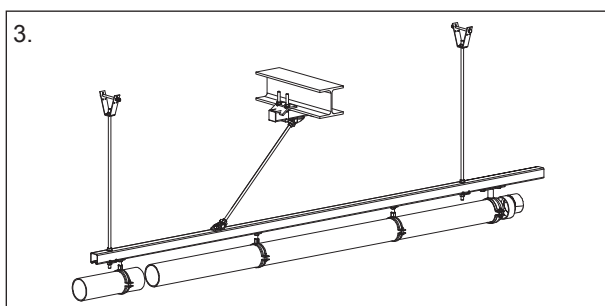
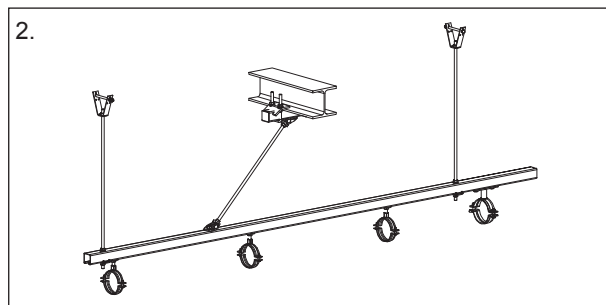
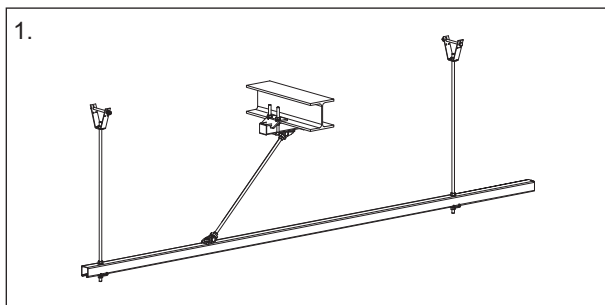

Pipework diagram in accordance with calculation

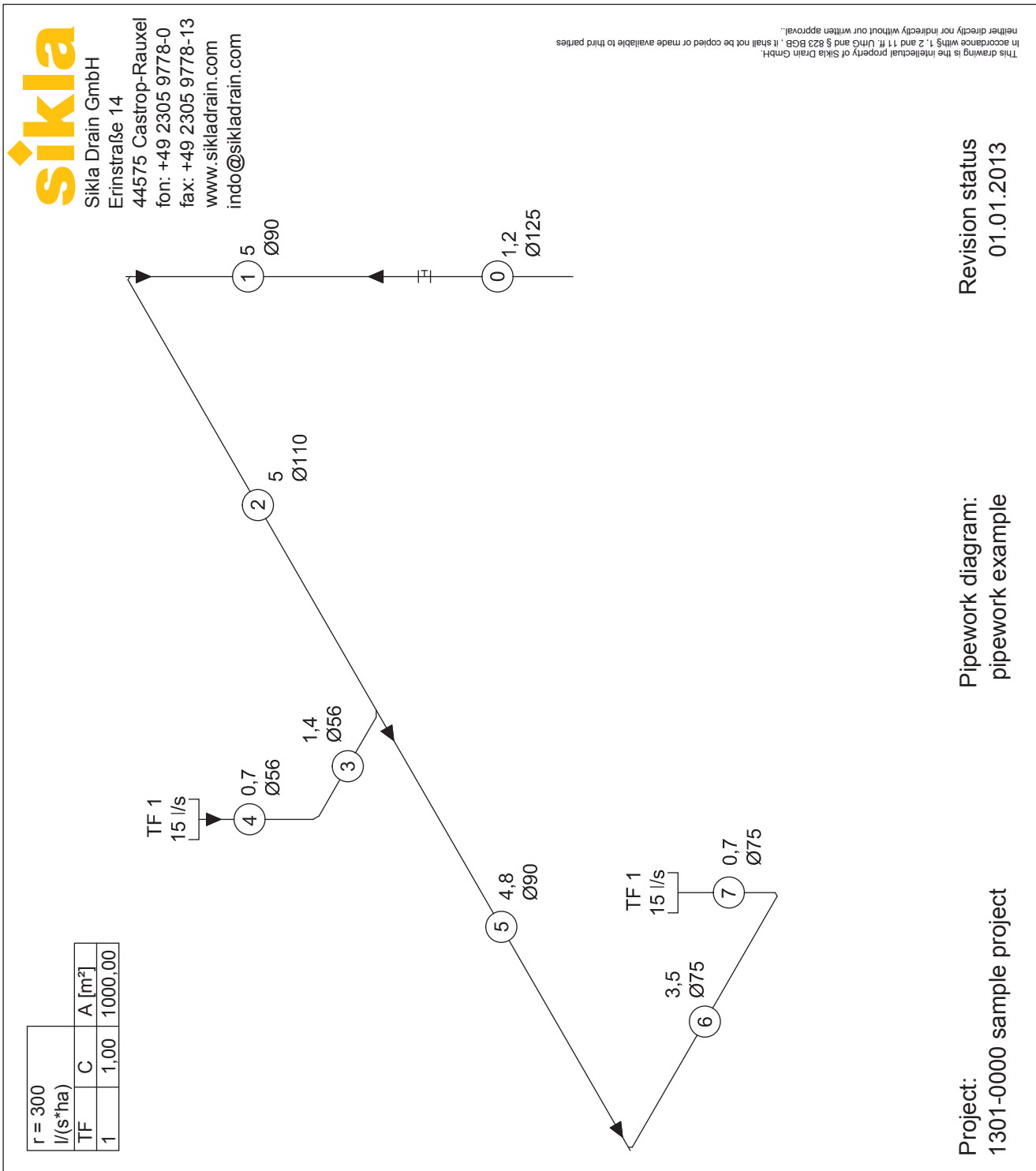

r = 300		
l/(s*ha)	C	A [m ²]
1	1,00	1000,00

Complete Installation

- Pos 1: Siaqua roof drains page 27 ff
- Pos 2: Siaqua fastening material: supporting rail page 37 ff
- Pos 3: Siaqua PE-HD material page 43 ff
- Pos 4: Siaqua structural fixtures page 59 ff
- Pos 5: Siaqua fire protection page 78

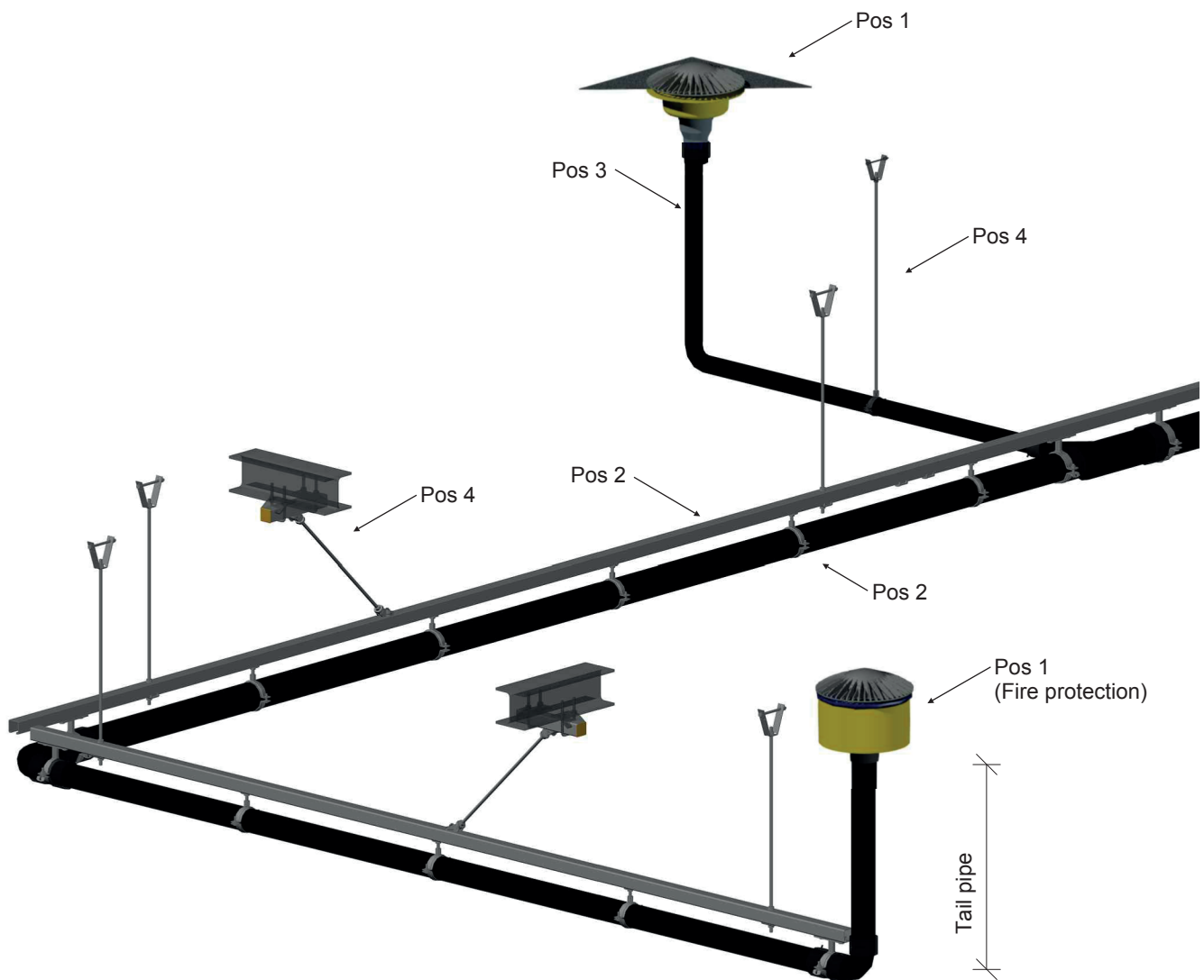

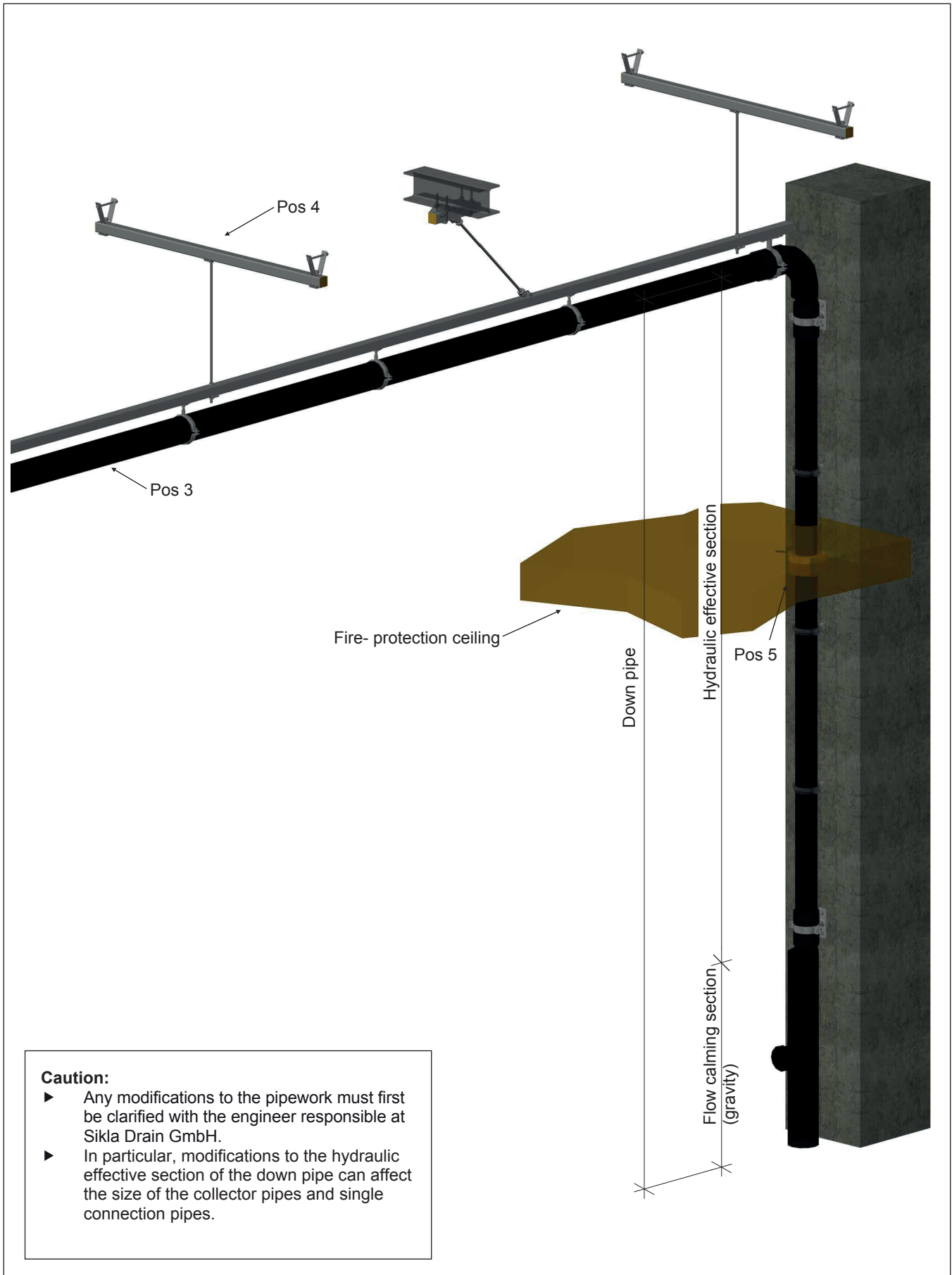

Fastening technology for PE-HD pipes

Pos 2: Siaqua fastening material: supporting rail

- Pos 2.1: Siaqua suspended rail fitting page 37
- Pos 2.2: Siaqua supporting railö page 38 f
- Pos 2.3: Siaqua standard fixture page 40
- Pos 2.4: Siaqua fixed point page 41

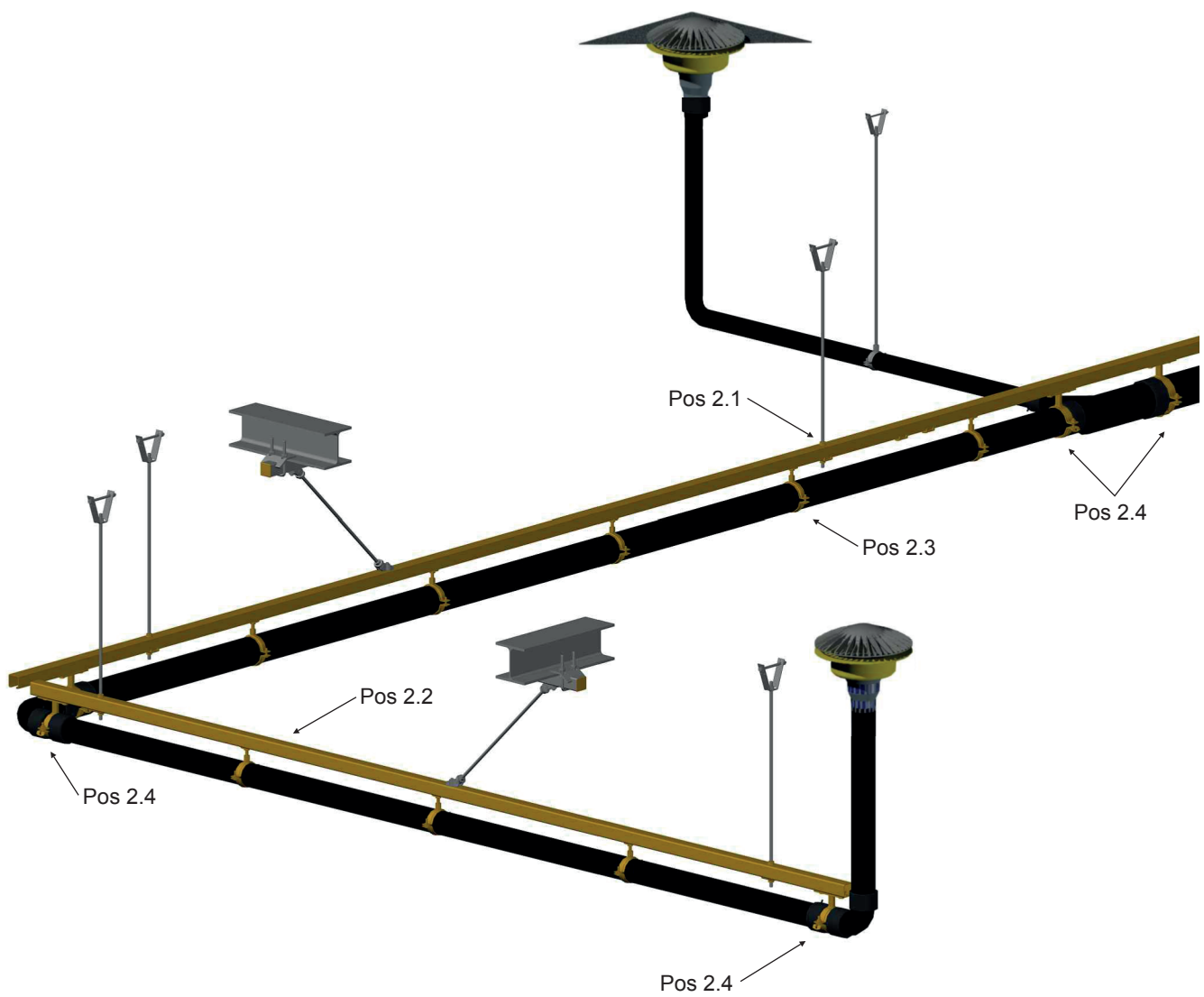

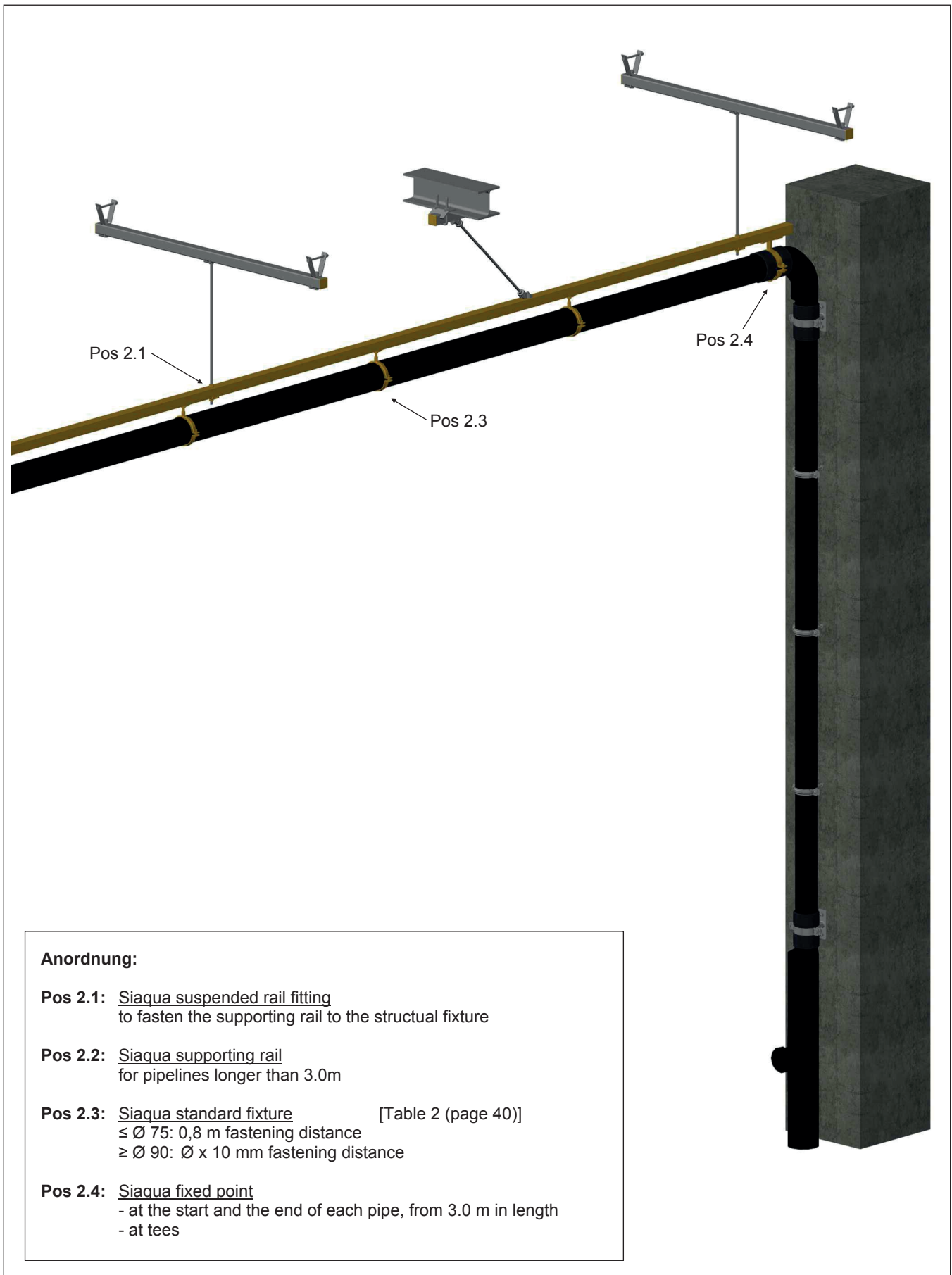

Siaqua PE-HD material

Pos 3: Siaqua PE-HD material

Pos 3.1: Siaqua pipelines	page 49
Pos 3.2: Siaqua fittings	page 50 ff
Pos 3.2.1: SDA socket SM	page 50
Pos 3.2.2: Siaqua tee	page 52 f
Pos 3.2.3: Siaqua elbow	page 54
Pos 3.2.4: Siaqua reducer / expansion	page 55
Pos 3.2.5: Siaqua cleaning pipe	page 56
Pos 3.3: Siaqua electro-fusion socket	page 56

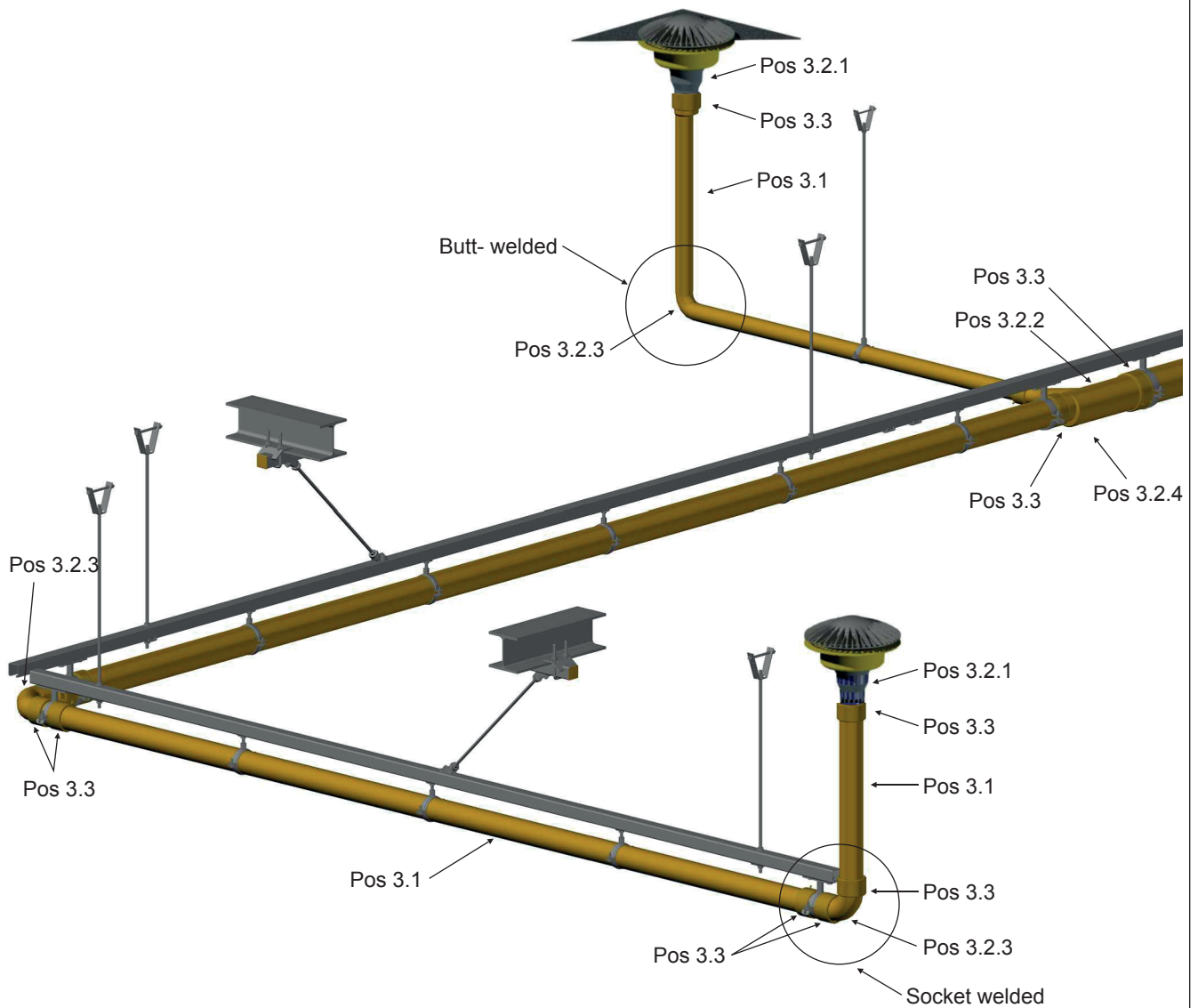

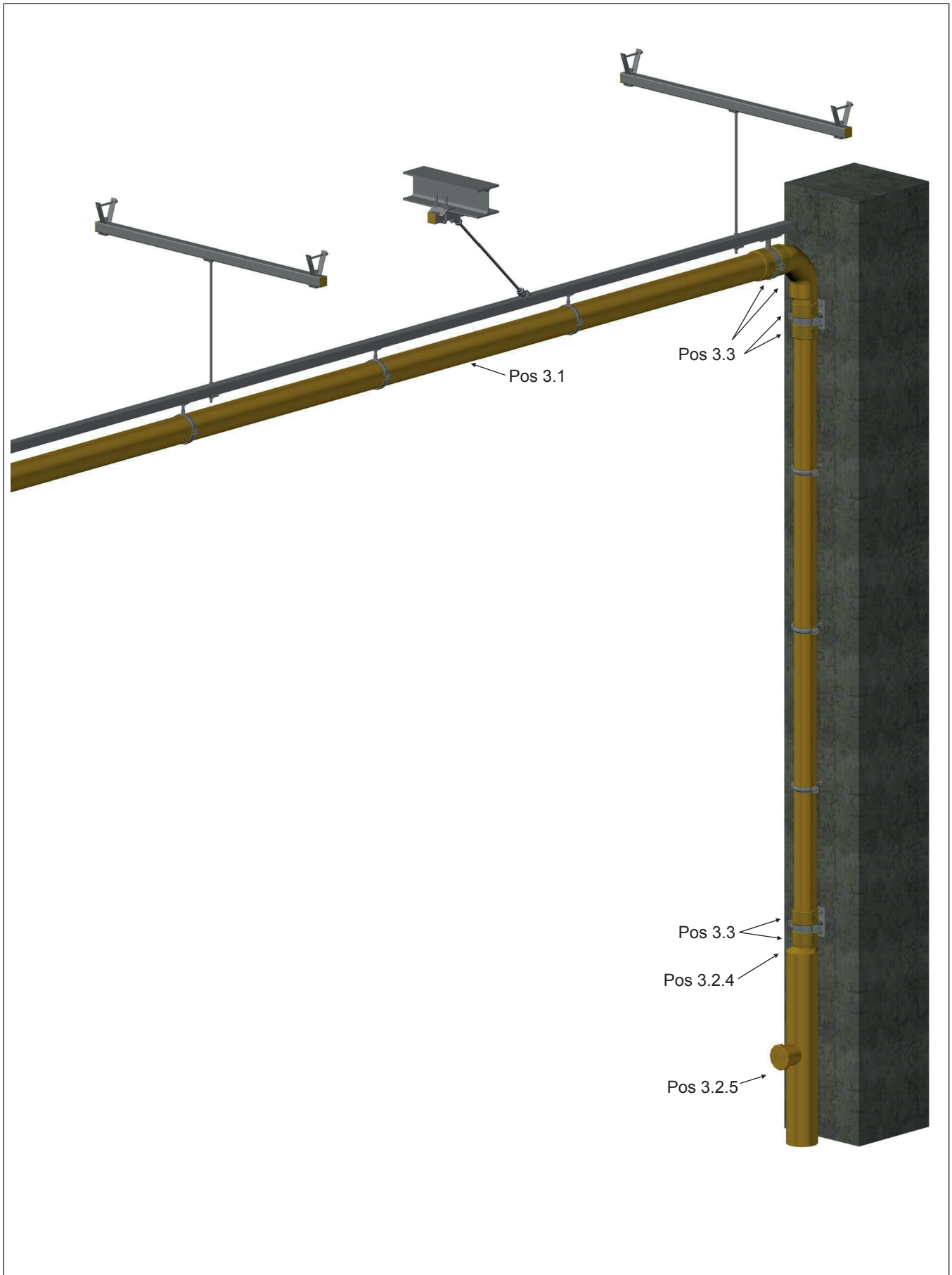

Fastening technology for fixing the drainage system to building structures

Pos 4: Siaqua structural fixtures

- Pos 4.1: Siaqua single joint page 60 f
- Pos 4.2: Siaqua structural joint page 62 ff
- Pos 4.3: Siaqua structural fixed point page 70
- Pos 4.4: Siaqua down pipe joint page 71 ff
- Pos 4.5: Siaqua down pipe fixed point page 74 ff
- Pos 4.6: Siaqua customised constructions designed to structural conditions page 77

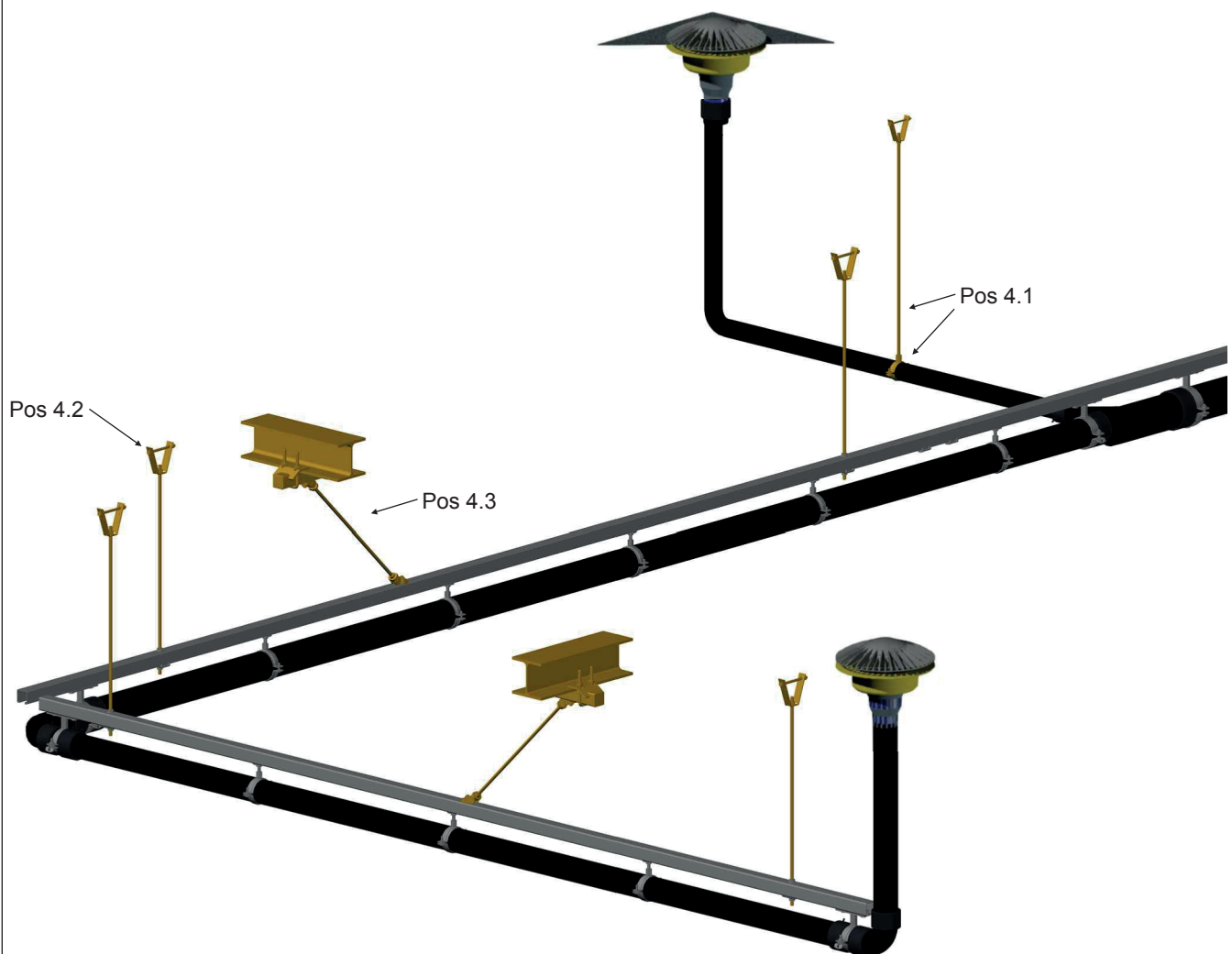

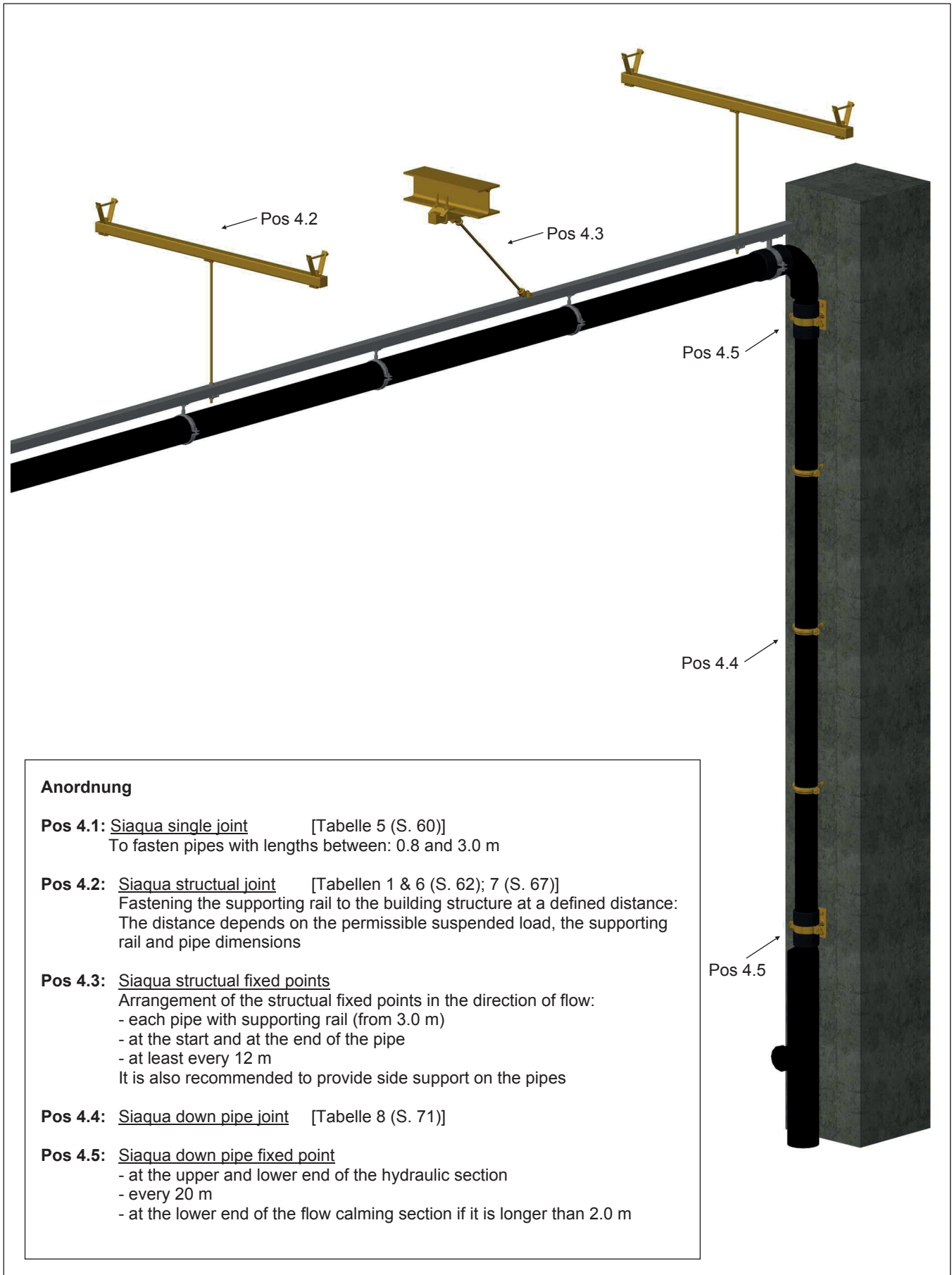

Anordnung

- Pos 4.1:** Siaqua single joint [Tabelle 5 (S. 60)]
To fasten pipes with lengths between: 0.8 and 3.0 m
- Pos 4.2:** Siaqua structural joint [Tabellen 1 & 6 (S. 62); 7 (S. 67)]
Fastening the supporting rail to the building structure at a defined distance:
The distance depends on the permissible suspended load, the supporting rail and pipe dimensions
- Pos 4.3:** Siaqua structural fixed points
Arrangement of the structural fixed points in the direction of flow:
 - each pipe with supporting rail (from 3.0 m)
 - at the start and at the end of the pipe
 - at least every 12 m
 It is also recommended to provide side support on the pipes
- Pos 4.4:** Siaqua down pipe joint [Tabelle 8 (S. 71)]
- Pos 4.5:** Siaqua down pipe fixed point
 - at the upper and lower end of the hydraulic section
 - every 20 m
 - at the lower end of the flow calming section if it is longer than 2.0 m

Siaqua fire protection

Pos 5: Siaqua fire protection

Pos 1.5: Siaqua fire protection roof drain page 32

Pos 5.1: Siaqua fire protection sleeve page 78

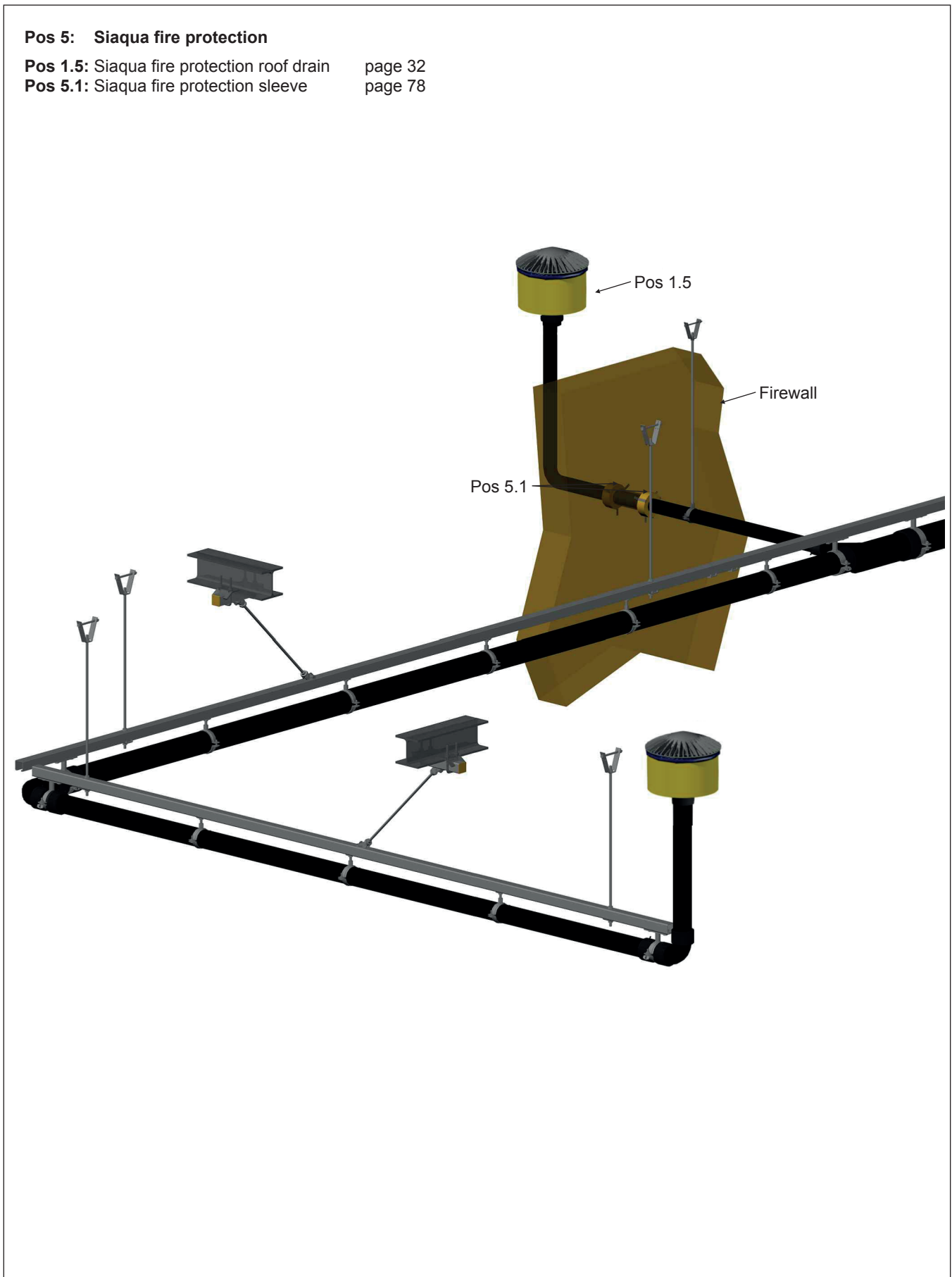

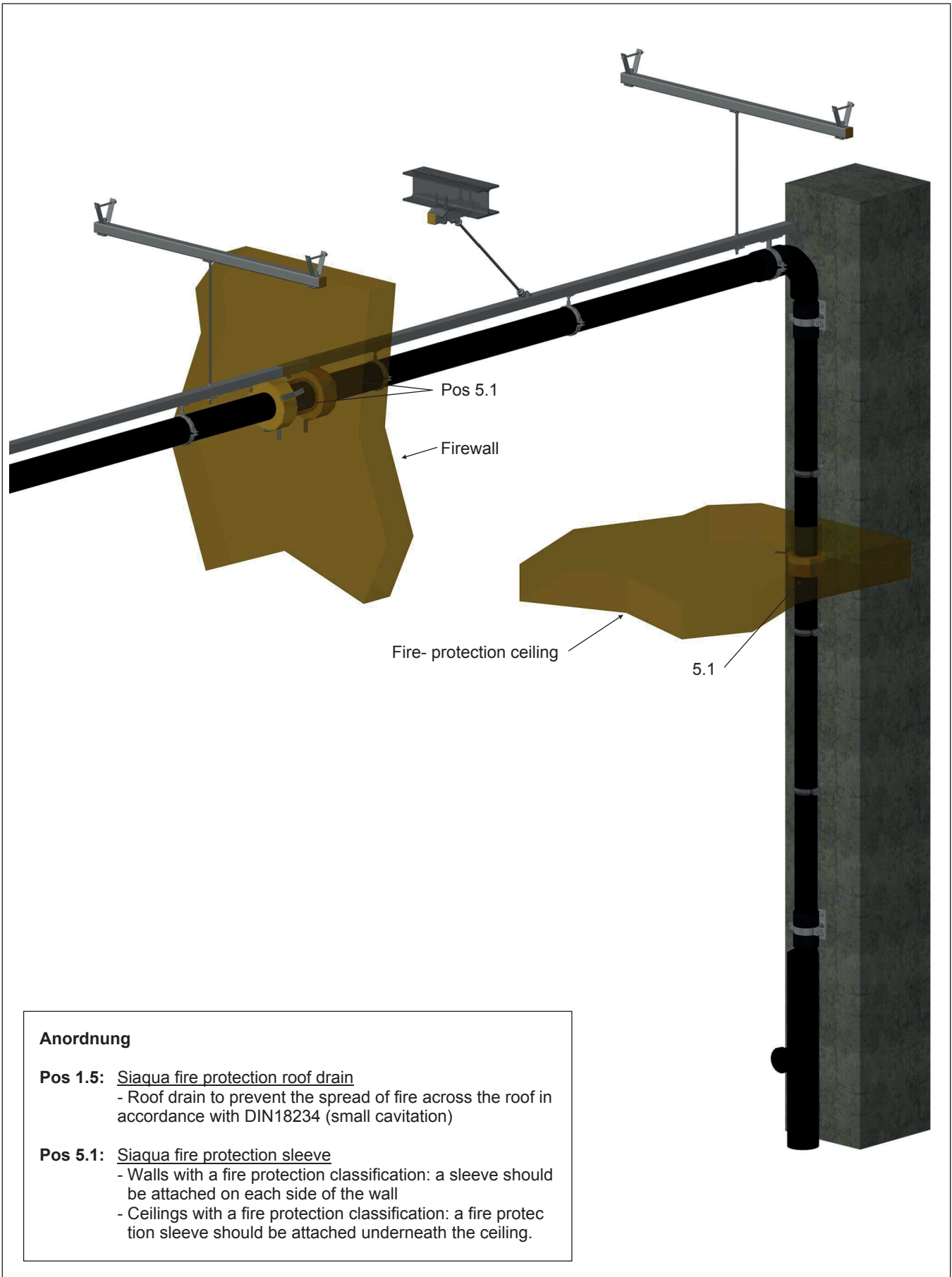

Anordnung

- Pos 1.5:** Siaqua fire protection roof drain
 - Roof drain to prevent the spread of fire across the roof in accordance with DIN18234 (small cavitation)
- Pos 5.1:** Siaqua fire protection sleeve
 - Walls with a fire protection classification: a sleeve should be attached on each side of the wall
 - Ceilings with a fire protection classification: a fire protection sleeve should be attached underneath the ceiling.

Assembly situation

General information

For choosing the right roof drain, the roof construction is crucial. It is advisable to check following details:

- Roof construction, insulation thickness
- Gutter installation, dimensions, material
- Intensive / extensive green roof
- Loads because of traffic
- Material of vapour barrier and roof foil

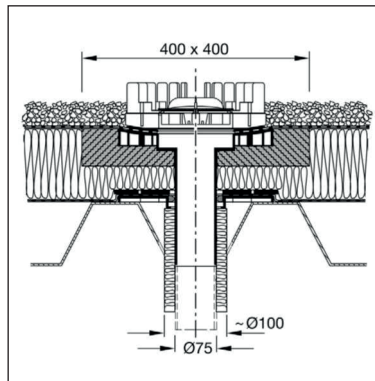
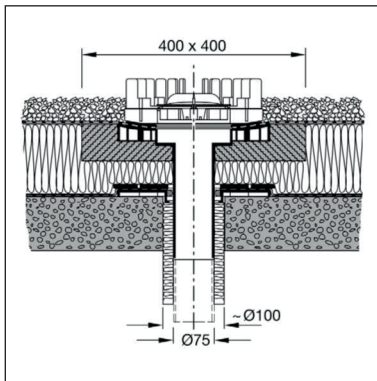

**PE roof drain -
warm roof
solid construction, lightweight construction**

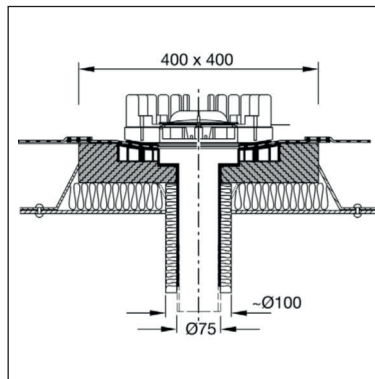
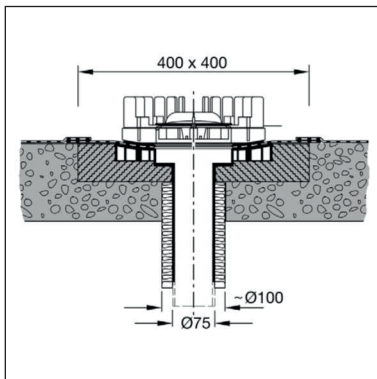

**PE roof drain -
cold dach
solid construction, lightweight construction**

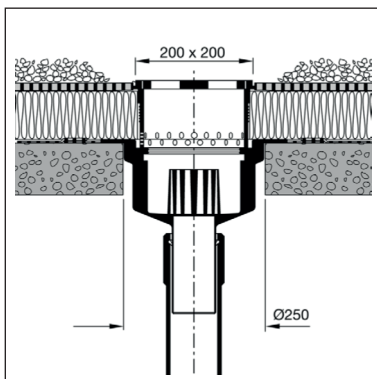

**PUR roof drain -
inverted roof
solid construction**

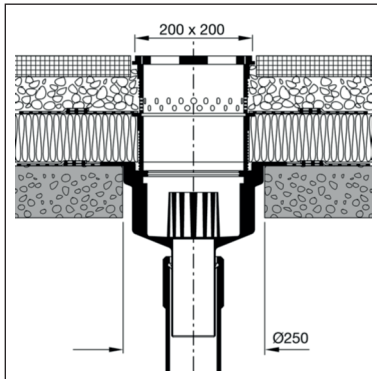

**PUR roof drain -
terrace passably - solid construction**

Tarraces, parking spots etc., which are realised with a protective layer made of concrete, the roof drains and pipes could start sintering because of easy soluble pieces. It is recommended to use a protective layer made from plastic or a gravel bed (grain size 16/32) around the roof drain with a size of ca 1x1 m.

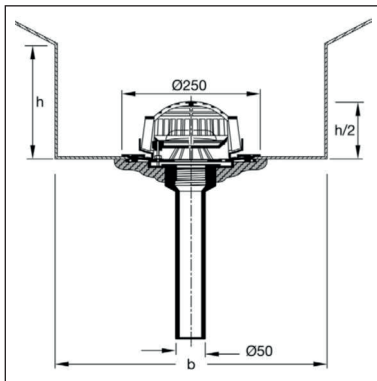

**Stainless steel roof drain with counterflange -
gutter installation**

On internal gutters or shed gutters at least two stainless steel roof drains with counterflange should be mounted. The end faces of the gutter are available for the emergency drainage. At these ends the emergency roof drain should be installed at half height ($h/2$) and the whole with (b) of the gutter.

The emergency drainage roof drain can be installed additionally on the long side when the gutter is mounted in front of the facade. The dimensioning depends on the slope of the gutter, the discharge capacity and the distance between the roof drains.

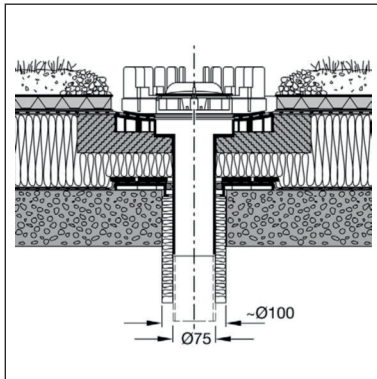

PE roof drain - warm roof solid construction - extensive / intensive greening

Roof greening is realised more often. It offers ecological, construction structure and economical advantages:

- Protection of the seal against damage (UV radiation, mechanical protection)
- Dust binding, climate improvement
- Sound insulation and retention effects

Two different kinds of roof greening are distinguished by vegetation and rainwater discharge:

- Extensive greening
- Intensive greening

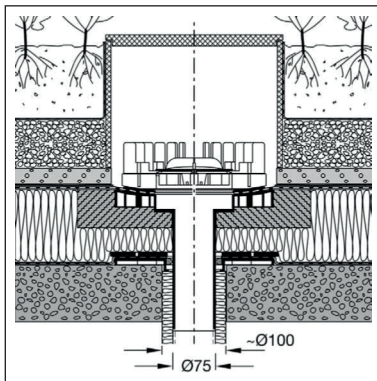

Extensive greening is characterized by low surface loads, small building heights and semi-natural vegetation. Extensive greening allows an economical greening of large roof areas.

Intensive greening is characterized by high surface loads, high building heights and intensive vegetation. Intensive greening grants optimal room for individualization.

Discharge coefficient C

Depending on the type of roof greening the discharge coefficient given by the producer of the drainage system needs to be taken.

Installation notes

The seeping- or surface water is not supposed to pollute the pipework or roof drains. According to the flat roof guideline every roof drain should be kept away from roof greening or gravel covering and should be accessible at all time.

To protect from pollution or plants a 30 to 50cm wide gravel loading to keep a safety distance between roof drain and roof greening should be provided.

To prevent fusion with limehydrate, the demands on carbon percentage of the drainage- and vegetation layer are limited to max. 25 g/l.

General control- and service instructions

If necessary the roof drains should be cleaned after completing installation of the roof structure. On Siphonic drainage systems the installation of the drains should be checked especially the air filters. The leaf and gravel guards should not be missing.

These mentioned things should be checked regularly.

PE-HD pipe system handling instructions

Transport and storage of PE-HD pipes

HDPE pipes must be secured from damage during transportation and when unloading and loading. When the pipes are unloaded, it is important to check for any transport damage. When lifting gear and equipment is used, it is recommended to use wide belts and cross beams for longer pipes.

All parts must be stored and handled under the same temperature conditions.

Non-palletised pipes should have full contact with the stack along the entire length and prevented from rolling. The load surface must not have any sharp objects.

Ensure that the storage area is level and clean where possible, in other words without stones or sharp objects. All pipes must be stored in a manner that protects them from being soiled on the inside.

Non-palletised pipes should not be stacked higher than one metre in height. This does not apply to palletised pipes if the pallets are supported with pallet frames. Do not remove the packing tapes until you are ready to install the pipes.

Make sure that the pipes do not come in contact with fuels, solvents, oils, grease, lubricants, paints or sources of heat. Do not scrape the pipes along the ground.

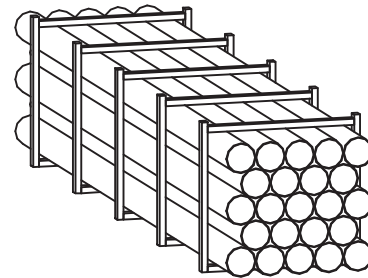

Production of connections of HDPE pipes and fittings

In accordance with DVS 2207-1 (Regulations from the Technical Committee of the German Welding Society), suitable measures must be taken to ensure suitable welding conditions when working at temperatures below 5°C. This also includes pre-heating or settling when applicable.

The pipes and fittings must be checked carefully for any transport damage and other impairments. They should be cleaned around the connection joints.

Scores, scratches and surface wear are admissible if they do not penetrate more than 10% into the minimum wall thickness of the pipe. Damaged parts must be removed.

The technical data of pipes and fittings must be checked to ensure they comply with the planning specifications in accordance with the markings.

A fine-toothed saw or a pipe cutter must be used to cut plastic pipes which must be cut at right angles.

Burrs and uneven surfaces have to be removed with a suitable tool, e.g. a scraper. Notches and incisions must be avoided.

Pipe ends that have been cut must be prepared to fit the type of connection used.

Welding work may only be carried out by qualified welders.

Pos 1 Siaqua roof drains and accessories

Roof drains

Siphonic drainage

SDA Speed roof drain - primary drainage	(Pos 1.1)	page 28
SDA Speed roof drain - emergency drainage	(Pos 1.2)	page 29

Gravity drainage

SDA Classic roof drain - primary drainage	(Pos 1.3)	page 30
SDA Classic roof drain - emergency drainage	(Pos 1.4)	page 31

Fire protection roof drain

Fire protection siphonic roof drain	(Pos 1.5.1)	page 32
Fire protection gravity roof drain	(Pos 1.5.2)	page 32

Accessoires

SDA fastening plate T220 for PUR	(Pos 1.6.1)	page 32
SDA overflow collar seal DU AS	(Pos 1.6.2.1)	page 32
SDA basic fitting seal DU GET	(Pos 1.6.2.2)	page 32
SDA clamp flange seal DUK	(Pos 1.6.2.3)	page 33
SDA extension fitting (ASE)	(Pos 1.6.3)	page 33
SDA primary drainage overflow collar AH	(Pos 1.6.4.1)	page 34
SDA emergency drainage overflow collar AN	(Pos 1.6.4.2)	page 34
SDA leaf and gravel guard LKF	(Pos 1.6.5)	page 36
Heating sleeve THM	(Pos 1.7)	S. 36

Note

- ▶ Customised roof drains
(z.B. Attica drains)
on request

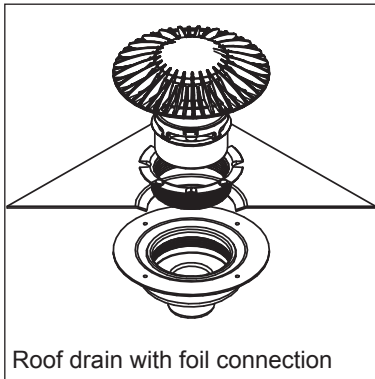

Roof drain with foil connection

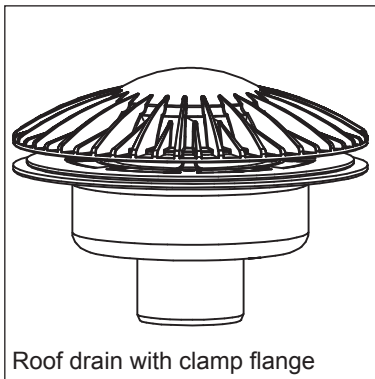

Roof drain with clamp flange

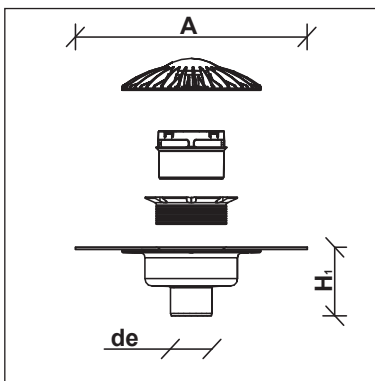

Pos 1.1 SDA Speed roof drain - primary drainage

Application

High-performance roof drain made of PUR integral foam for the primary drainage in a siphonic drainage system in accordance with DIN 1253.

Scope of delivery

SDA basic fitting (GET) with foamed sleeve or press-fit flange and pre-assembled functional part (comprising SDA leaf and gravel guard (LKF), SDA overflow collar and SDA overflow collar seal).

Installation

Installation in accordance with the roofer trade guidelines and the currently valid and approved engineering guidelines as well as the enclosed installation instructions.

Foil connection: The existing roof membrane is sealed to the integrated connecting sleeve on site by following the sealing method recommended by the specific manufacturer.

Clampflange: The single-layer plastic roof membrane or vapour barrier membrane must be sealed on site using the press-fit flange

A socket with snap ring (SDA socket (SM) (pos. 3.2.1.1)) is used to connect type 70 to the HDPE drain pipe to positively lock to the pipe system. With type 125, the connection is made with a standard HDPE socket or long sleeve socket and a single joint.

Technical data

Material: SDA basic fitting GET made of PUR integral foam, blue functional part made of PP, black, DMEP seal

Nominal capacity: Type 70: up to 15,6 l/s
Type 125: up to 24,3 l/s

Pos. no.		Type	suitable for	d _e [mm]	A [mm]	H ₁ [mm]	G [kg]	Pack. [m]	Art.No.
1.1.1.1	SDA Speed 70 PVC 15 G	DN 70	Sikaplan PVC 15 G	90	500	135	2,44	1	601013
1.1.1.2	SDA Speed 70 FPO 15	DN 70	FPO 15	90	500	135	2,44	1	601146
1.1.1.3	SDA Speed 70 Bitumen B	DN 70	Bitumen B	90	500	135	2,54	1	601015
1.1.1.4	SDA Speed 70 Klemmflansch K	DN 70	Klemmflansch	90	500	135	2,80	1	601018
1.1.3.1	SDA Speed 125 PVC 15 G	DN 125	Sikaplan PVC 15 G	125	500	135	2,40	1	601021
1.1.3.2	SDA Speed 125 FPO 15	DN 125	FPO 15	125	500	135	2,40	1	601149
1.1.3.3	SDA Speed 125 Bitumen B	DN 125	Bitumen B	125	500	135	2,50	1	601023
1.1.3.4	SDA Speed 125 Klemmflansch K	DN 125	Klemmflansch	125	500	135	2,76	1	601025

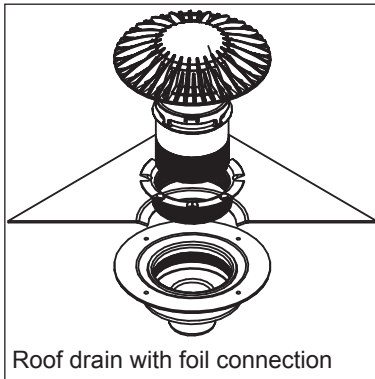

Roof drain with foil connection

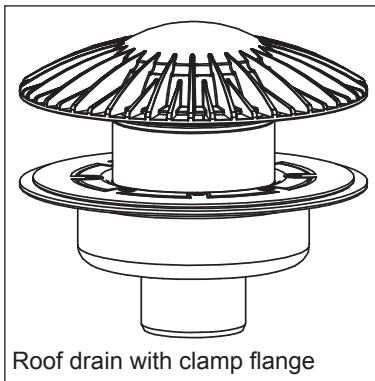

Roof drain with clamp flange

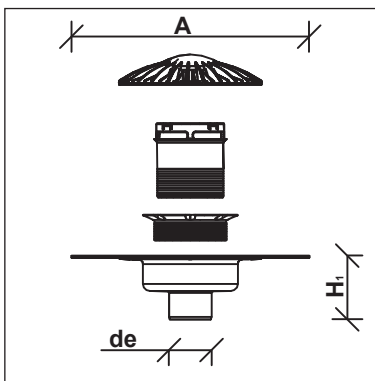

Pos 1.1 SDA Speed roof drain - primary drainage

Application

High-performance roof drain made of PUR integral foam for the primary drainage in a siphonic drainage system in accordance with DIN 1253.

Scope of delivery

SDA basic fitting (GET) with foamed sleeve or press-fit flange and pre-assembled functional part (comprising SDA leaf and gravel guard (LKF), SDA overflow collar and SDA overflow collar seal).

Installation

Installation in accordance with the roofer trade guidelines and the currently valid and approved engineering guidelines as well as the enclosed installation instructions. The emergency drainage overflow collar must be adjusted to the specified length.

Foil connection: The existing roof membrane is sealed to the integrated connecting sleeve on site by following the sealing method recommended by the specific manufacturer.

Clampflange: The single-layer plastic roof membrane or vapour barrier membrane must be sealed on site using the press-fit flange

A socket with snap ring (SDA socket (SM) (pos. 3.2.1.1)) is used to connect type 70 to the HDPE drain pipe to positively lock to the pipe system. With type 125, the connection is made with a standard HDPE socket or long sleeve socket and a single joint.

Technical data

Material: SDA basic fitting GET made of PUR integral foam, blue functional part made of PP, black, DMEP seal

Nominal capacity: Type 70: up to 15,6 l/s
Type 125: up to 29,2 l/s

Pos. No.		Type	suitable for	d _e [mm]	A [mm]	H ₁ [mm]	G [kg]	Pack. [m]	Art.No.
1.2.1.1	SDA Speed 70 PVC 15 G AEN	DN 70	Sikaplan PVC 15 G	90	500	135	2,44	1	601103
1.2.1.2	SDA Speed 70 FPO 15 AEN	DN 70	FPO 15	90	500	135	2,44	1	601147
1.2.1.3	SDA Speed 70 Bitumen B AEN	DN 70	Bitumen B	90	500	135	2,54	1	601100
1.2.1.4	SDA Speed 70 Klemmflansch K AEN	DN 70	Klemmflansch	90	500	135	2,80	1	601102
1.2.3.1	SDA Speed 125 PVC 15 G AEN	DN 125	Sikaplan PVC 15 G	125	500	135	2,40	1	601110
1.2.3.2	SDA Speed 125 FPO 15 AEN	DN 125	FPO 15	125	500	135	2,40	1	601150
1.2.3.3	SDA Speed 125 Bitumen B AEN	DN 125	Bitumen B	125	500	135	2,50	1	601107
1.2.3.4	SDA Speed 125 Klemmflansch K AEN	DN 125	Klemmflansch	125	500	135	2,76	1	601108

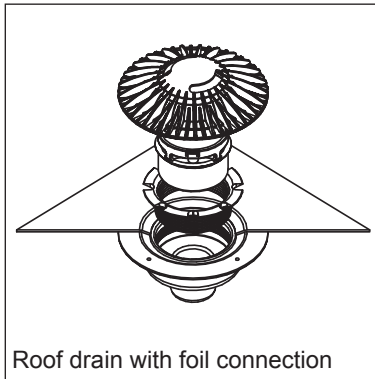

Roof drain with foil connection

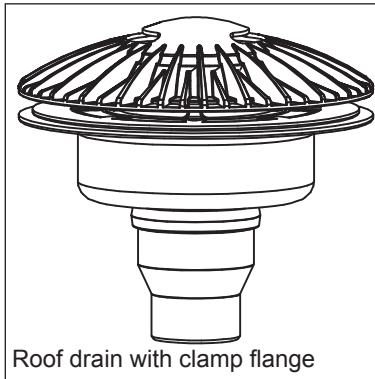

Roof drain with clamp flange

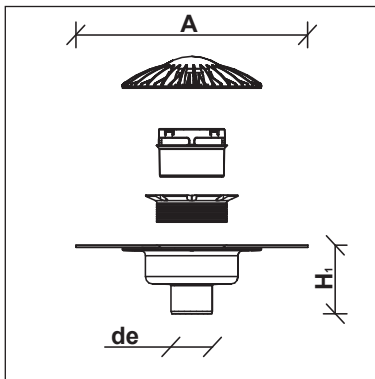

Pos 1.3 SDA Classic roof drain - primary drainage

Application

High-performance roof drain made of PUR integral foam for the primary drainage in a gravity drainage system.

Scope of delivery

SDA basic fitting (GET) with foamed sleeve or press-fit flange and pre-assembled functional part (comprising SDA leaf and gravel guard (LKF), SDA overflow collar and SDA overflow collar seal).

Installation

Installation in accordance with the roofer trade guidelines and the currently valid and approved engineering guidelines as well as the enclosed installation instructions.

Foil connection: The existing roof membrane is sealed to the integrated connecting sleeve on site by following the sealing method recommended by the specific manufacturer.

Clampflange: The single-layer plastic roof membrane or vapour barrier membrane must be sealed on site using the press-fit flange

A socket with snap ring (SDA socket (SM) (pos. 3.2.1.1)) is used to connect type 70 to the HDPE drain pipe to positively lock to the pipe system. With type 125, the connection is made with a standard HDPE socket or long sleeve socket and a single joint.

Technical data

Material: SDA basic fitting GET made of PUR integral foam, blue functional part made of PP, black, DMEP seal

Nominal capacity: Type 70: up to 11,4 l/s
 Type 110: up to 13,8 l/s
 Type 125: up to 19,5 l/s

Pos. No.		Type	suitable for	de [mm]	A [mm]	H1 [mm]	G [kg] [kg/m]	Pack. [m]	Art.No.
1.3.1.1	SDA Classic 70 PVC 15 G	DN 70	Sikaplan PVC 15 G	90	500	135	2,44	1	601041
1.3.1.2	SDA Classic 75 FPO 15	DN 70	FPO 15	90	500	135	2,44	1	601140
1.3.1.3	SDA Classic 70 Bitumen B	DN 70	Bitumen B	90	500	135	2,54	1	601043
1.3.1.4	SDA Classic 70 Klemmflansch K	DN 70	Klemmflansch	90	500	135	2,80	1	601046
1.3.2.1	SDA Classic 110 PVC 15 G	DN 100	Sikaplan PVC 15 G	110	500	135	2,42	1	601049
1.3.2.2	SDA Classic 110 FPO 15	DN 100	FPO 15	110	500	135	2,42	1	601142
1.3.2.3	SDA Classic 110 Bitumen B	DN 100	Bitumen B	110	500	135	2,52	1	601051
1.3.2.4	SDA Classic 110 Klemmflansch K	DN 100	Klemmflansch	110	500	135	2,78	1	601053
1.3.3.1	SDA Classic 125 PVC 15 G	DN 125	Sikaplan PVC 15 G	125	500	135	2,40	1	601055
1.3.3.2	SDA Classic 125 FPO 15	DN 125	FPO 15	125	500	135	2,40	1	601144
1.3.3.3	SDA Classic 125 Bitumen B	DN 125	Bitumen B	125	500	135	2,50	1	601057
1.3.3.4	SDA Classic 125 Klemmflansch K	DN 125	Klemmflansch	125	500	135	2,76	1	601059

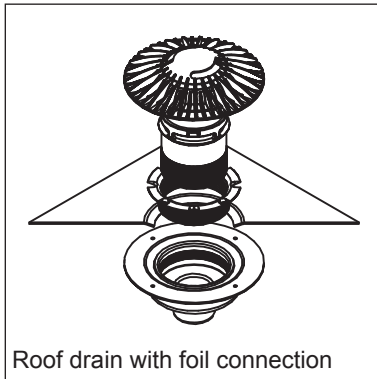

Roof drain with foil connection

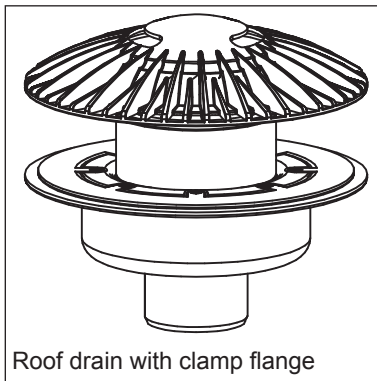

Roof drain with clamp flange

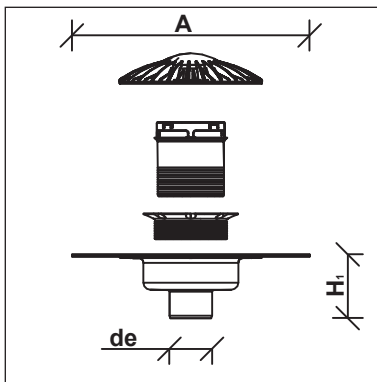

Pos 1.4 SDA Classic roof drain - emergency drainage

Application

High-performance roof drain made of PUR integral foam for the primary drainage in a gravity drainage system.

Scope of delivery

SDA basic fitting (GET) with foamed sleeve or press-fit flange and pre-assembled functional part (comprising SDA leaf and gravel guard (LKF), SDA overflow collar and SDA overflow collar seal).

Installation

Installation in accordance with the roofer trade guidelines and the currently valid and approved engineering guidelines as well as the enclosed installation instructions. The emergency drainage overflow collar must be adjusted to the specified length.

Foil connection: The existing roof membrane is sealed to the integrated connecting sleeve on site by following the sealing method recommended by the specific manufacturer.

Clampflange: The single-layer plastic roof membrane or vapour barrier membrane must be sealed on site using the press-fit flange

A socket with snap ring (SDA socket (SM) (pos. 3.2.1.1)) is used to connect type 70 to the HDPE drain pipe to positively lock to the pipe system. With type 125, the connection is made with a standard HDPE socket or long sleeve socket and a single joint.

Technical data

Material: SDA basic fitting GET made of PUR integral foam, blue functional part made of PP, black, DMEP seal

Nominal capacity: Type 70: up to 11,4 l/s
 Type 110: up to 13,8 l/s
 Type 125: up to 19,5 l/s

Pos. No.		Type	suitable for	de [mm]	A [mm]	H1 [mm]	G [kg] [kg/m]	Pack. [m]	Art.No.
1.4.1.1	SDA Classic 70 PVC 15 G AEN	DN 70	Sikaplan PVC 15 G	90	500	135	2,44	1	601114
1.4.1.2	SDA Classic 75 FPO 15 AEN	DN 70	FPO 15	90	500	135	2,44	1	601141
1.4.1.3	SDA Classic 70 Bitumen B AEN	DN 70	Bitumen B	90	500	135	2,54	1	601111
1.4.1.4	SDA Classic 70 Klemmflansch K AEN	DN 70	Klemmflansch	90	500	135	2,80	1	601113
1.4.2.1	SDA Classic 110 PVC 15 G AEN	DN 100	Sikaplan PVC 15 G	110	500	135	2,42	1	601117
1.4.2.2	SDA Classic 110 FPO 15 AEN	DN 100	FPO 15	110	500	135	2,42	1	601143
1.4.2.3	SDA Classic 110 Bitumen B AEN	DN 100	Bitumen B	110	500	135	2,52	1	601115
1.4.2.4	SDA Classic 110 Klemmflansch K AEN	DN 100	Klemmflansch	110	500	135	2,78	1	601054
1.4.2.1	SDA Classic 125 PVC 15 G AEN	DN 125	Sikaplan PVC 15 G	125	500	135	2,40	1	601121
1.4.2.2	SDA Classic 125 FPO 15 AEN	DN 125	FPO 15	125	500	135	2,40	1	601145
1.4.2.3	SDA Classic 125 Bitumen B AEN	DN 125	Bitumen B	125	500	135	2,50	1	601118
1.4.2.4	SDA Classic 125 Klemmflansch K AEN	DN 125	Klemmflansch	125	500	135	2,76	1	601120

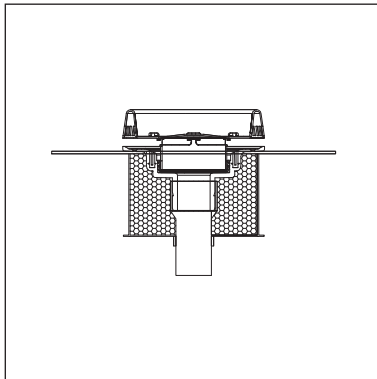

Pos 1.5 Siaqua fire protection roof drain

Application

Roof drain outlet to prevent the spread of fire across the roof in accordance with DIN 18234 (minor cavitation).

Technical data

Fire protection roof drain in accordance with DIN EN 1253

Pos. Nr.	Type	Art.No.
1.5.1	Siphonic	on request
1.5.2	Gravity	on request

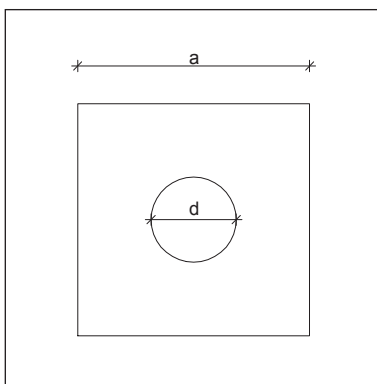

Pos 1.6.1 SDA fastening plate T 235/220 for PUR roof drain

Application

Suitable for installation on roofs clad with trapezoidal sheet metal in accordance with DIN 18807-3. The fastening plate can be used for the roof outlet type 70 as well as for the roof outlet types 100 or 125.

Technical data

Material: Galvanised sheet metal

Pos. Nc.	Type	a [mm]	d [mm]	s [mm]	G [kg]	Pack. [m]	Art.No.
1.6.1.1	SDA BFB T 220	600	220	1,5	2,2	1	601039
1612	SDA BFB T 235	600	235	1,5	2,2	1	600169

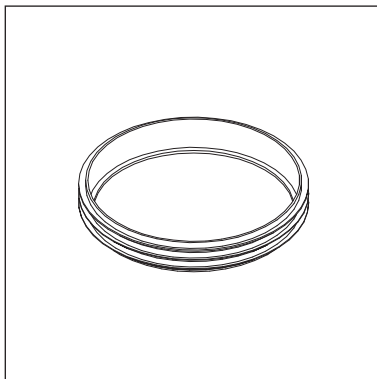

Pos 1.6.2.1 SDA overflow collar seal (DU AS)

Application

The SDA overflow collar seal (DU AS) is used to connect the overflow collar to the basic or extension drain fitting.

Technical data

Material: DMEP

Pos. No.	Type	G [kg]	Pack. [m]	Art.No.
1.6.2.1	SDA DU AS	0,04	1	601069

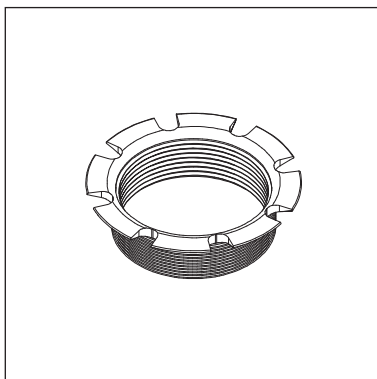

Pos 1.6.2.2 SDA basic fitting seal (DU GET)

Application

The SDA basic fitting seal is used to attach the extension fitting to the basic drain fitting.

Technical data

Pos. No.	Type	G [kg]	Verp. [m]	Art.No.
1.6.2.2	SDA DU GET	0,16	1	601122

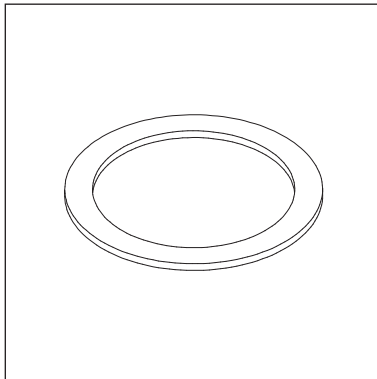

Pos 1.6.2.3 SDA clamp flange seal (DUK)

Application

The SDA clamp flange seal (DUK) is used to seal the seal membrane to the basic drain fitting.

Technical data

Material: closed-cell cellular rubber, DMEP

Pos. No.	Type	G [kg]	Pack. [m]	Art.No.
1.6.2.3	SDA DUK	0,16	1	601063



Aufstockelement mit Folienanschluss

Pos 1.6.3 SDA extension fitting ASE

Application

The SDA extension fitting (ASE) is used to bridge the insulation and can be used for both siphonic and gravity drainage.

Scope of delivery

PUR extension fitting with integrated connecting sleeve or press-fit flange, SDA basic drain fitting seal (DU GET).

Installation

Installation in accordance with the roofer trade guidelines and the currently valid and approved engineering guidelines.

Foil connection: The roof membrane is sealed to the integrated connecting sleeve on site by following the sealing method recommended by the specific manufacturer.

Clamp flange: The single-layer plastic roof membrane or vapour barrier membrane must be sealed on site using the press-fit flange.

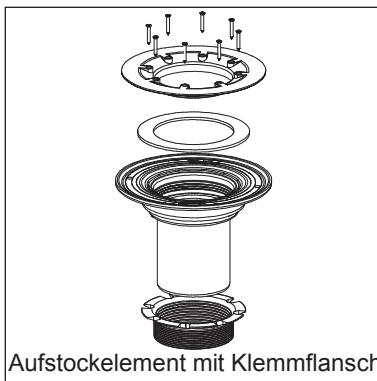

Aufstockelement mit Klemmflansch

Technical data

Material (structure or building): PUR

Pos. No.	max. Bridgeable insulation height [mm]	suitable for	d _e [mm]	A [mm]	H ₁ [mm]	G [kg]	Pack. [m]	Art.No.
1.6.3.1.1	160	Sikaplan PVC 15 G	140	500	215	1,80	1	601027
1.6.3.2.1	210	Sikaplan PVC 15 G	140	500	265	2,00	1	601028
1.6.3.3.1	260	Sikaplan PVC 15 G	140	500	315	2,20	1	601029
1.6.3.3.2	260	FPO 15	140	500	315	2,70	1	601136
1.6.3.2.3	210	Bitumen B	140	500	265	2,60	1	601031
1.6.3.3.3	260	Bitumen B	140	500	315	2,80	1	601032
1.6.3.1.4	160	Klemmflansch	140	500	215	2,20	1	601033
1.6.3.2.4	210	Klemmflansch	140	500	265	2,40	1	601034
1.6.3.3.4	260	Klemmflansch	140	500	315	2,60	1	601035

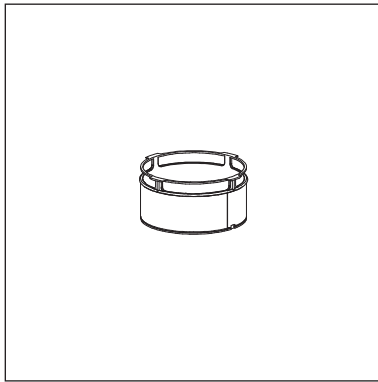

Pos 1.6.4.1 SDA primary drainage overflow collar (AH)

Application

The SDA primary drainage overflow collar (AH) is used to connect the leaf and gravel guard to all types of the SDA basic drain fitting or SDA extension fitting.

Scope of delivery

SDA emergency drainage overflow collar AH

Installation

The SDA overflow collar seal (DU AS) (pos. 1.6.2.1) is inserted onto the overflow collar from underneath and screwed into the retaining brackets of the leaf and gravel guard. The functional part is then inserted into the basic drain fitting or extension drain fitting

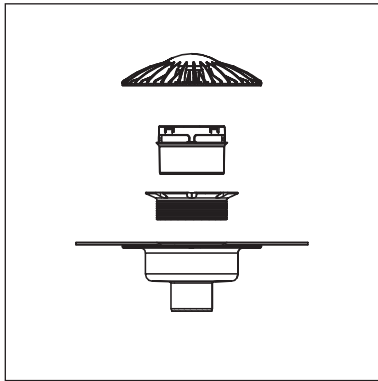

Technical data

Material: MM-PP BE 21

Pos. No.	Type	G [kg]	Pack. [m]	Art.No.
1.6.4.1	SDA AH	0,07	1	601066

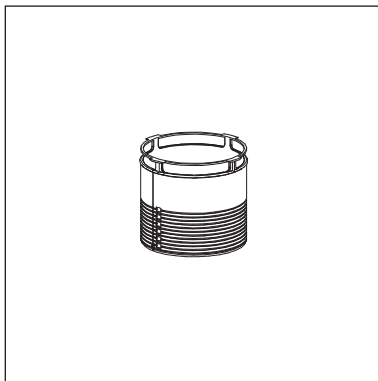

Pos 1.6.4.2 SDA emergency drainage overflow collar (AN)

Application

The SDA emergency drainage overflow collar (AN) is used to increase the overflow height for an emergency drainage system. The raised overflow height of the overflow collar (AN) ensures that no rain water can leak into the emergency drainage system with normal quantities of rainfall. The overflow collar can be shortened depending on the required overflow height.

Scope of delivery

SDA emergency drainage overflow collar AN

Installation

The emergency drainage overflow collar must be adjusted to the specified length. The SDA overflow collar seal (DU AS) (pos. 1.6.2.1) is inserted onto the overflow collar from underneath and screwed into the retaining brackets of the leaf and gravel guard. The functional part is then inserted into the basic drain fitting or extension drain fitting.

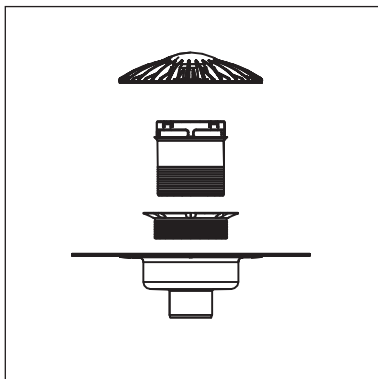

Technical data

Material: MM-PP BE 21

Pos. No.	Type	G [kg]	Pack. [m]	Art.No.
1.6.4.2	SDA AEN	0,34	1	601038

Setting height of the Siaqua overflow collar (AN) for emergency drainage [mm]

Siaqua SDA Speed roof drain DN 70

Method

The required setting height is calculated based on the pipework diagram (page 5) for the primary drainage and the diagram below. The litre capacity of the primary roof drain can be found on the pipework diagram for the primary drainage. With this value, you can then calculate the required overflow height using the diagram below.

Example

Outlet capacity according to pipework diagram on page 5: 15 [l/s]
 The overflow collar must be shortened to 45 mm.

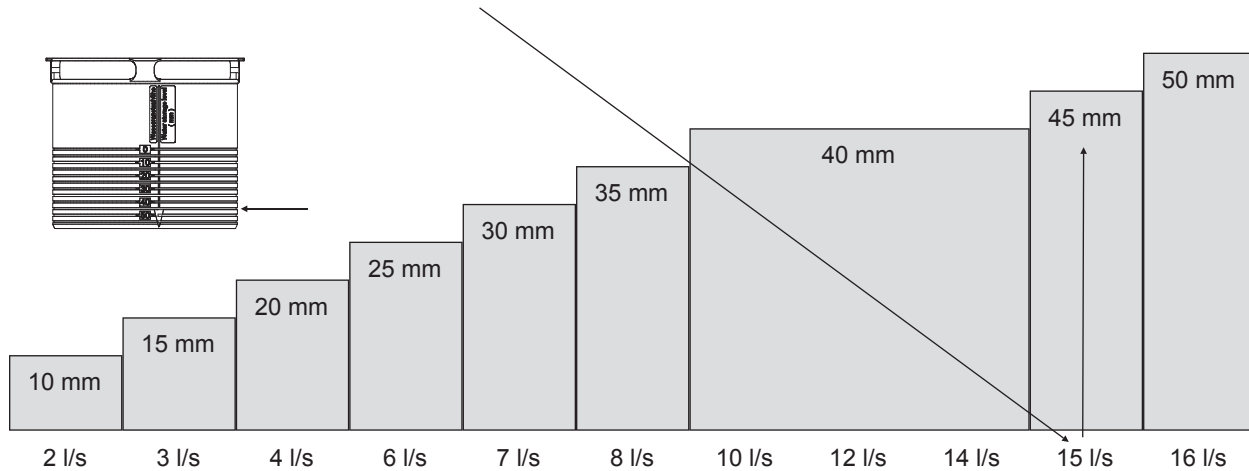

Outlet capacity of primary drainage. Valid for SDA Speed primary drainage, type 70

Note

- ▶ If an outlet capacity is not indicated, round the capacity off to the next integral number.
- ▶ Beispiel:
5,2 l/s => overflow height: 25 mm

Siaqua SDA Speed roof drain DN 125

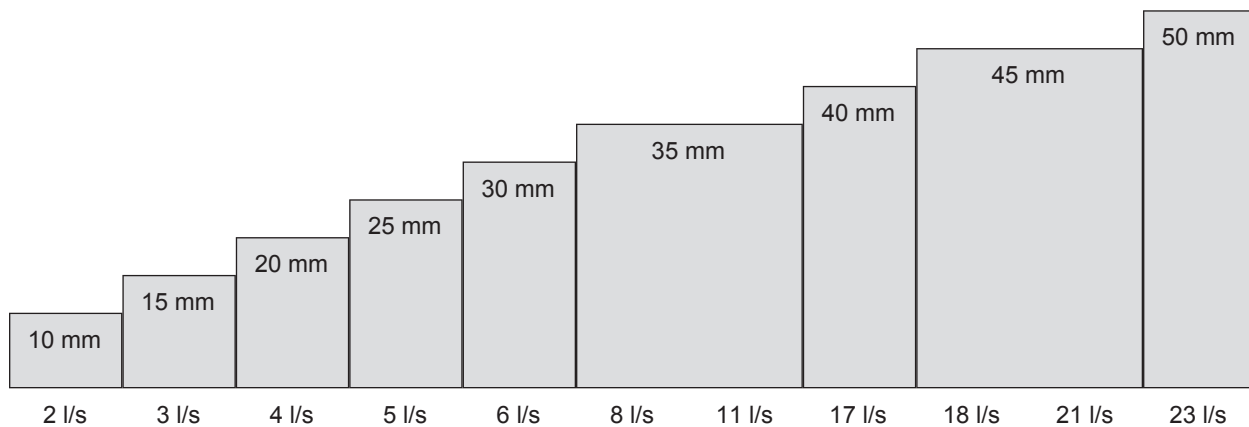

Outlet capacity of primary drainage. Valid for SDA Speed primary drainage, type 125

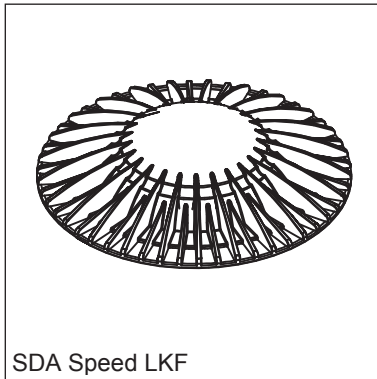

SDA Speed LKF

Pos 1.6.5 SDA leaf and gravel guard LKF

Application

The SDA leaf and gravel guard (LKF) ensures the efficient functioning of the roof drainage by preventing the infiltration of leaves, gravel and dirt into the drainage system. This design has been especially developed for siphonic drainage to prevent air entering into the pipe system and allows high drainage capacities even at low overflow heights. Alternative leaf and gravel guards are also available for gravity drainage with slots which allow the required air to enter into the pipe system and prevent the pipes from overflowing.

Scope of delivery

SDA leaf and gravel guard LKF

Installation

The SDA overflow collar (pos. 1.6.4) is screwed onto the retaining brackets underneath the SDA leaf and gravel guard (LKF) and inserted into the basic or extension fitting using the SDA overflow collar seal (pos. 1.6.2.1) .

Technical data

Material: MM-PP BE 21

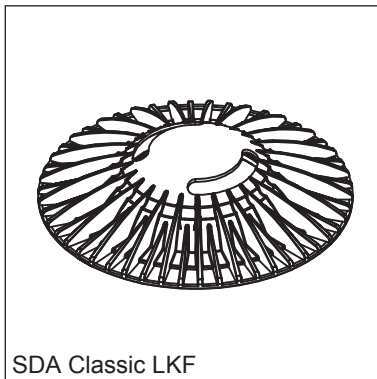

SDA Classic LKF

Pos. No.	Type	G [kg]	Pack. [m]	Art.No.
1.6.5.1	SDA Speed LKF	0,39	1	601067
1.6.5.2	SDA Classic LKF	0,37	1	601068

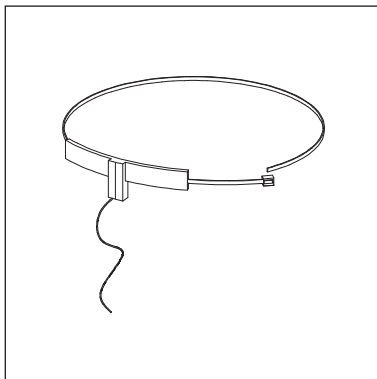

Pos 1.7 Heating sleeve THM

Application

Self-regulating heating sleeve to heat the roof drains. Fasten to connection pipe. Also ideal for retrofitting.

Installation

Attach the heating sleeve directly on the drain's connection pipe under the fastening plate and fasten using the cable ties. A transformer is not required for heating. Only qualified electricians may connect and install the heating sleeves by observing the VDE guidelines.

Technical data

230 V
10 W
for outlets ≥ DN 70

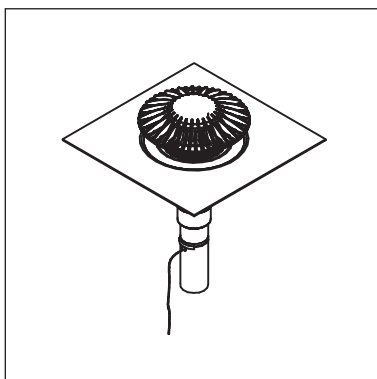

Pos. No.	Type	G [kg]	Pack. [m]	Art.No.
1.7	THM	0,27	1	601040

Pos 2 Fixture technology for PE-HD pipework

Siaqua suspended rail fitting	(Pos 2.1)	page 37
Siaqua supporting rail	(Pos 2.2)	page 38f
Siaqua standard fixture	(Pos 2.3)	page 40
Siaqua fixed point	(Pos 2.4)	page 41

General

The Siaqua fixture system includes the pipe fixture to the supporting rail as well as the supporting rail and the connection to the structural fixtures.

Three types of supporting rails are available. The type used depends on the pipe dimensions and fastening.

distance required. The pipe fixture is divided into two categories:

- ◆ Standard fixture to support vertical loads
- ◆ Fixed points to securely fasten the pipes

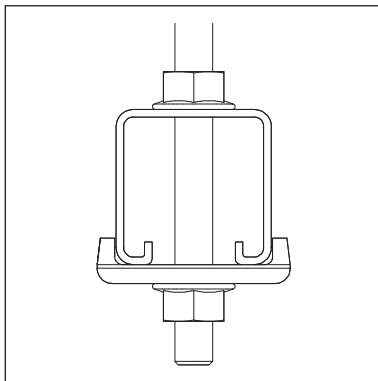

Pos 2.1 Siaqua suspended rail fitting

Application

The Siaqua suspended rail fitting is used to connect the supporting rail to the structural joint

Scope of delivery

M10 retaining bracket
2x M10 flange nut

Installation

The flange nut is screwed onto the threaded rod. Insert the threaded rod through the supporting rail. Slide the retaining bracket onto the threaded rod and securely fasten using the flange nut. Use the lower flange nut to set the required height of the supporting rail. Securely fasten the supporting rail with the upper flange nut.

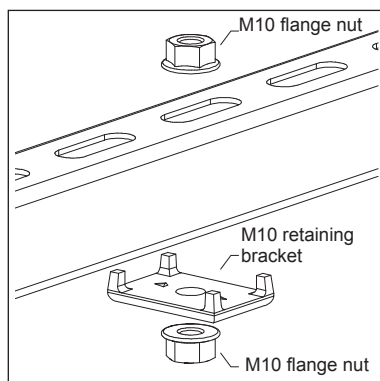

Article number

Position number	Art.No.
2.1	602104

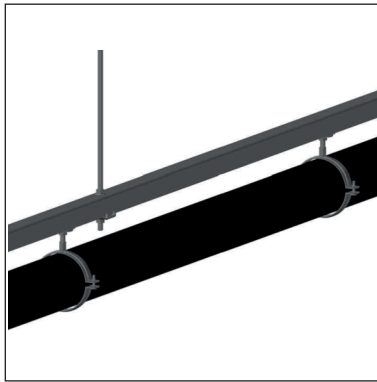

Pos 2.2.1 Siaqua supporting rail

Application

An installation rail to securely support the load resulting from the net weight, hydraulics and temperature.

For the convenient and correct manufacturing of cross beams, wall brackets and supporting frames.

Arrangement

In general, all straight pipes over 3 m in length must be fixed with a supporting rail. Exception: sections where Siaqua fixtures are connected directly to the building structure.

The installation rail is used to fasten to the building structure.

Scope of delivery

The supporting rail supplied in 6m lengths

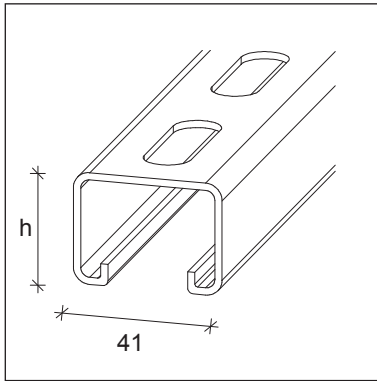

Technical data

Fastening the supporting rail in centres of:

	≤ DN 100	DN 125	DN 150	DN 200	DN 250	DN 300
Type I	3,0 [m]	2,8 [m]	2,4 [m]	1,5 [m]	–	–
Type II	3,0 [m]	3,0 [m]	3,0 [m]	2,3 [m]	1,2 [m]	–
Type III	3,0 [m]	3,0 [m]	3,0 [m]	3,0 [m]	2,1 [m]	1,1 [m]

Table 1: permissible fastening distances for Siaqua supporting rails

Article numbers

Position number	Type	h [mm]	G [Kg/m]	I _y [cm ⁴]	W _y [cm ³]	Art.No.
2.2.1.1	Typ I	31	1,64	2,77	1,60	198889
2.2.1.2	Typ II	41	1,97	5,16	2,43	193747
2.2.1.3	Typ III	52	2,82	11,20	4,16	193785

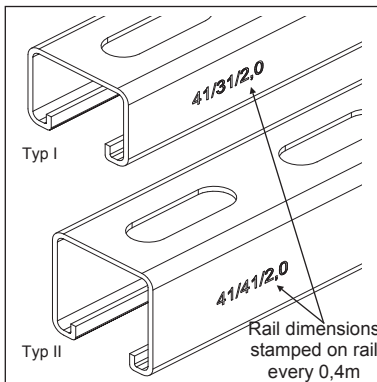

Note

- ▶ Observe specifications on projectspecific pipework diagrams
- ▶ Customised rails on request
- ▶ Rail dimensions stamped on rail every 0,4m

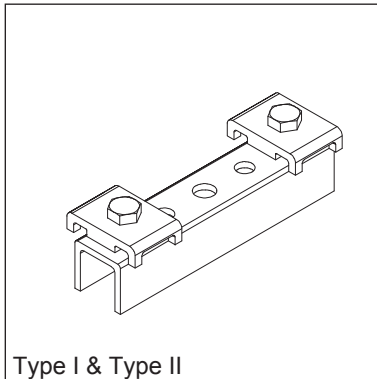

Pos 2.2.2 Siaqua rail coupling

Application

The rail coupling is used to conveniently and securely extend and connect installation rails on the construction site or in factory pre-production.

Scope of delivery

Retaining bracket type 41 and corresponding hexagonal head screws are loosely supplied.

Installation

All the supplied fittings should be installed to ensure the static values.

Article numbers

Position number	Type	Art.No.
2.2.2.1	Typ I	177599
2.2.2.2	Typ II	155115
2.2.2.3	Typ III	155608

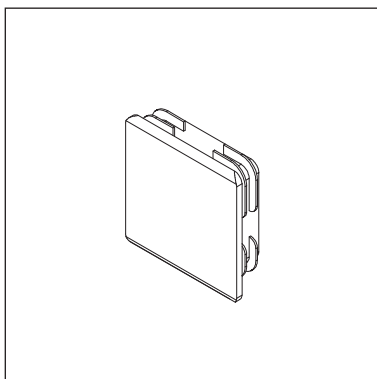
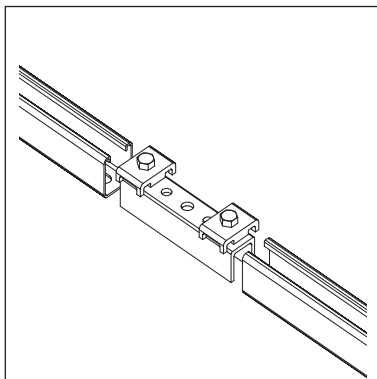
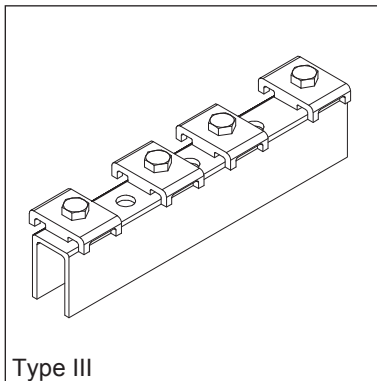

Pos 2.2.3 Siaqua cover cap

Application

A protective cap used to cleanly finish the ends of all Sikla installation rails.

Article numbers

Position number	Type	Art.No.
2.2.3.1	Typ I	110477
2.2.3.2	Typ II	177689
2.1.3.3	Typ III	177698

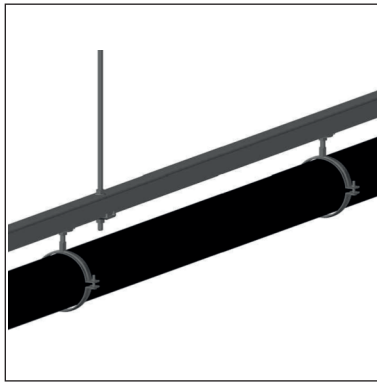

Pos 2.3 Siaqua standard fixture: installation rail SB MS

Application

Standardfastening of PE-HD pipe to the supporting rail

Arrangement

The fastening distance should be selected according to the table below:

Type	DN	40	50	56	63	70	90	100	125	150	200	250	300
Pipeclip distance [m]		0,8	0,8	0,8	0,8	0,8	0,9	1,1	1,2	1,6	2,0	2,5	3,1

Table 2: Permissible fastening distances for Siaqua standard fixture.

Scope of delivery

2G threaded pipe clip, suitable for sizes 40 to 150 and the pre-assembled M10 clamp adapter.

Stabil D3G pipe clip, suitable for sizes 200 to 300 and the pre-assembled clamp adapter M16.

Installation

The complete assembly is pushed into the rail opening and engages automatically. When setting the distance to the next fixture, the assembly is routed into the rail and securely attached. The hexagonal nut is then tightened.

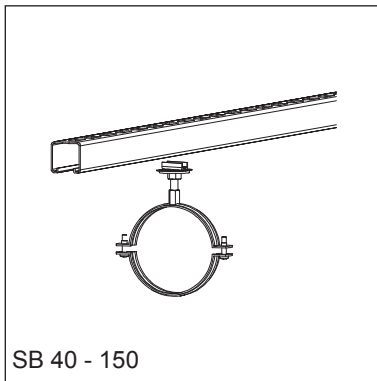

Article numbers

Position number	Type	without insert	with insert
2.3.1	DN 40	602200	602205
2.3.2	DN 50	602210	602215
2.3.3	DN 56	602220	602225
2.3.4	DN 63	602230	602235
2.3.5	DN 70	602240	602245
2.3.6	DN 90	602250	602255
2.3.7	DN 100	602260	602265
2.3.8	DN 125	602270	602275
2.3.9	DN 150	602280	602285
2.3.10	DN 200	602290	602295
2.3.11	DN 250	602300	602305
2.3.12	DN 300	602310	602315

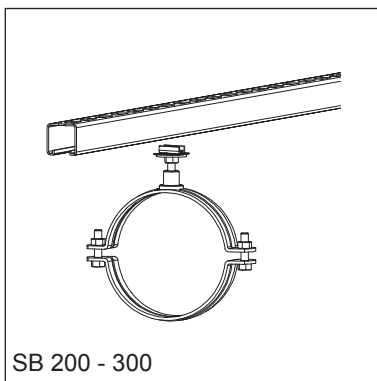

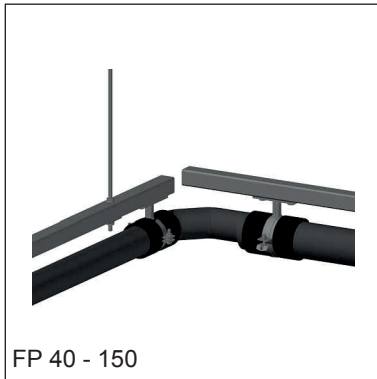

FP 40 - 150

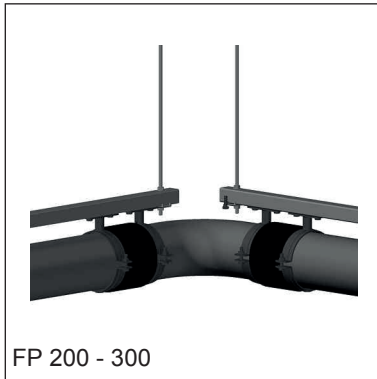

FP 200 - 300

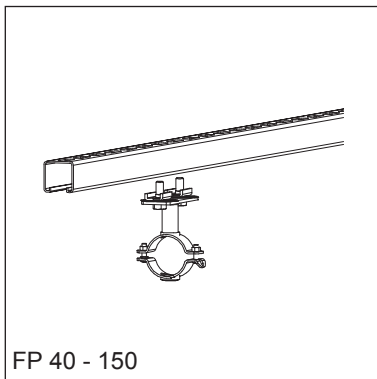

FP 40 - 150

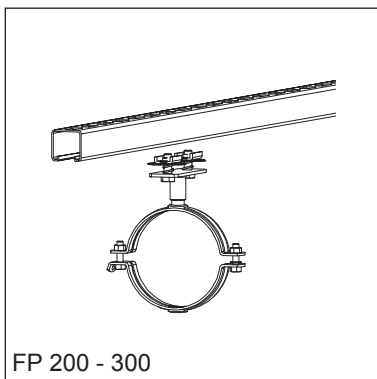

FP 200 - 300

Pos 2.4 Siaqua installation rail fixed point FP MS

Application

Fixed point construction to securely support the load resulting from the Siaqua siphonic systems.

Arrangement

In general, a fixed point must be fitted at the start and end of all straight pipes with the same diameters from a length of 3 [m].

The fixed points should be fitted as intermediary fixed points in front of and behind every tee.

Scope of delivery

Stabil D-3G pipe clip(s) suitable for sizes 40 to 300 and the pre-installed fixed point adapter with single threaded connection.

Installation

The complete fixed point assembly is pushed into the rail opening and engages automatically. When setting the distance to the next fixture, the assembly is routed into the rail and securely attached. The hexagonal head screw is then tightened.

Note

The fixed points should always be inserted together with electro-fusion sockets. See examples on page 81 ff.

Article numbers

Position numbers	Type	without insert	with insert
2.4.1	DN 40	602320	602325
2.4.2	DN 50	602330	602335
2.4.3	DN 56	602340	602345
2.4.4	DN 63	602350	602355
2.4.5	DN 70	602360	602365
2.4.6	DN 90	602370	602375
2.4.7	DN 100	602380	602385
2.4.8	DN 125	602390	602395
2.4.9	DN 150	602400	602405
2.4.10	DN 200	600940	600941
2.4.11	DN 250	600942	600943
2.4.12	DN 300	600944	600945

Pos 3 PE-HD Material

Handling instructions for the PE-HD pipe system

Transport and storage of PE-HD pipes	page 44
Production of connections of PE-HD pipes and fittings	page 44
Handling guidelines for electro-fusion welded connections	page 45
Heated- tool butt welding handling guidelines	page 48

PE-HD Parts

PE-HD pipes	(Pos 3.1)	page 49
Siaqua fittings	(Pos 3.2)	
SDA socket SM	(Pos 3.2.1.1)	page 50
PE-HD socket	(Pos 3.2.1.2)	page 50
PE-HD long sleeve socket	(Pos 3.2.1.3)	page 51
PE-HD tee	(Pos 3.2.2)	page 52 f
PE-HD elbow	(Pos 3.2.3)	page 54
PE-HD reducer	(Pos 3.2.4)	page 55
PE-HD cleaning pipe	(Pos 3.2.5)	page 56
PE-HD electro-fusion socket	(Pos 3.3)	page 56

Accessoires

Sleeve welder for PE-HD	page 57
Gravity welding equipment for PE-HD	page 57
Pipe cutter for PE-HD	page 57
Processing tools for PE-HD	page 57

PE-HD pipe system handling instructions

Transport and storage of PE-HD pipes

HDPE pipes must be secured from damage during transportation and when unloading and loading. When the pipes are unloaded, it is important to check for any transport damage. When lifting gear and equipment is used, it is recommended to use wide belts and cross beams for longer pipes.

All parts must be stored and handled under the same temperature conditions.

Non-palletised pipes should have full contact with the stack along the entire length and prevented from rolling. The load surface must not have any sharp objects.

Ensure that the storage area is level and clean where possible, in other words without stones or sharp objects. All pipes must be stored in a manner that protects them from being soiled on the inside.

Non-palletised pipes should not be stacked higher than one metre in height. This does not apply to palletised pipes if the pallets are supported with pallet frames. Do not remove the packing tapes until you are ready to install the pipes.

Make sure that the pipes do not come in contact with fuels, solvents, oils, grease, lubricants, paints or sources of heat. Do not scrape the pipes along the ground.

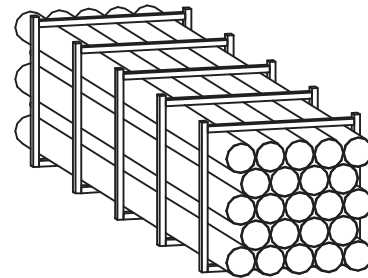

Production of connections of HDPE pipes and fittings

In accordance with DVS 2207-1 (Regulations from the Technical Committee of the German Welding Society), suitable measures must be taken to ensure suitable welding conditions when working at temperatures below 5°C. This also includes pre-heating or settling when applicable.

The pipes and fittings must be checked carefully for any transport damage and other impairments. They should be cleaned around the connection joints.

Scores, scratches and surface wear are admissible if they do not penetrate more than 10% into the minimum wall thickness of the pipe. Damaged parts must be removed.

The technical data of pipes and fittings must be checked to ensure they comply with the planning specifications in accordance with the markings.

A fine-toothed saw or a pipe cutter must be used to cut plastic pipes which must be cut at right angles.

Burrs and uneven surfaces have to be removed with a suitable tool, e.g. a scraper. Notches and incisions must be avoided.

Pipe ends that have been cut must be prepared to fit the type of connection used.

Welding work may only be carried out by qualified welders.

Processing guidelines electro-fusion socket

1 Check working environment

When working with temperatures below 5°C and/or rain and wind, make sure you have a working space which is dry and sufficiently temperatured.

2 Provide correct electrical connection

Check stability and height of voltage. Especially when working with generators and long power cables.

3 Check system tools/system components

Making a welded connection, components according to DIN have to be used.



4a Cut pipe ends evenly and square to the pipe axis

It is recommended to use a PE pipe cutter. The cut is made evenly, square to the pipe axis and with no splinters. Check the pipe ends with a circumferential measuring tape.

Information

If the pipe ends are not cut evenly the insertion area of the electro fusion socket won't be fulfilled. This could lead to an electrical bypass because of exposed heating wires and the needed welding pressure can not be reached.



4b Deburr pipe ends

If the pipe ends are cut with a saw it is necessary to deburr the pipe ends.



5 Measure for peeling section length on electro-fusion socket. Formula for peeling length: Electro-fusion socket / 2 + 10mm.

Measure for peeling length on pipe and mark the spot.

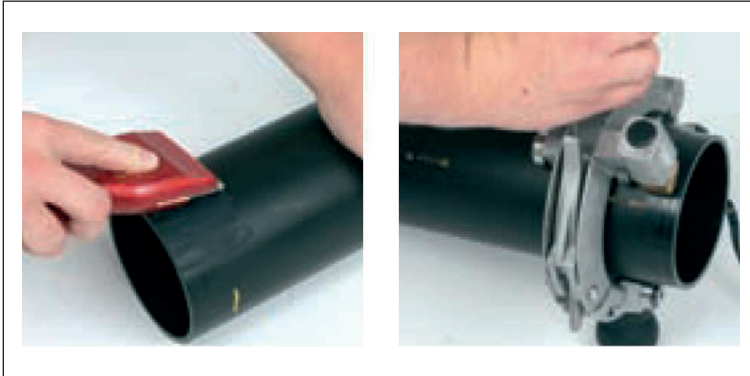

- 6** Before welding the pipe surfaces and every system component have to be peeled around the whole insertion area.
Cut removal 0,2 mm

Reccomendation:

Use a radial peeling tool for consistent cut removal.



- 7** After peeling, the surface has to be cleaned with a special PE cleaning product and a Clean, lint free cloth. Until welding make sure the cleaned welded zone is kept away from dirt.

Mark insertion length.

When using the electro-fusion socket as double socket the peeling length is equal to the socket length. Remove pipe center stop carefully with a knife. Do not damage the heating wires.



- 8** Clean the inside of the welding socket with a clean, lint free cloth and the PE cleaning product. Wait a few seconds until the socket is dried up.



- 9** After preparing the pipe ends and system components they can be insert in the prepared socket. Use the whole insertion length and make sure the pipe is mounted without tension.



10 Welding is carried out in accordance with the welding machine instructions.

Note:

The scope of delivery comprises two welding cables (green and brown).

Dimension	welding cable
DN 40-150	green
DN 200-300	brown

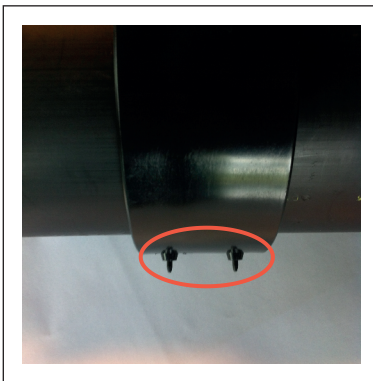

11 Welding indicators show if enough welding pressure was build during the welding process. If the welding indicators are visible and the welding was performed according to the previous steps, the welding has been carried out correctly.

If the indicators are not visible cut the socket out.

Do not weld a second time.

Until cooling time is over the pipe and sockets has to be stored tension free and protected against positional change (see table cooling time).

Welding time

Dimensions	Welding time (ca.) [S]
DN 40-150	82
DN 200-300	370

Cooling time

DN	40	50	56	63	70	90	110	125	150	200	250	300
Min. Pipe [mm]	39,6	49,6	55,6	62,6	74,6	89,6	109,6	124,6	159,6	199,6	249,6	314,6
Cooling time [min]	10	10	10	10	15	15	15	15	15	20	20	20

Heated-tool butt welding guidelines

1. Protect your place of work from weather influences (ambient temperature at least +5°C)
Check the equipment is working correctly, set the correct clamping range and pre-heat.
2. Align the pipe/fitting and clamp securely (without tension).
3. Plane the front of the pipes so that they are parallel.
4. Remove any dirt and chips from the welding zone.
5. Check the pipe offset (max. 0.1 x wall thickness) and width of gap (max. 0.5 mm).
6. Clean the pipe ends using a cleaner and paper.
7. Check that the heated tool is clean and has reached the required temperature (210 ±10°C).
8. Butt heat fusion: Once the heated tool is applied, the pipes are pressed together onto the heated tool by applying the defined fusion pressure.
9. Once the specified bead height has been reached (0.5 - 2.0 mm), the pressure is reduced.
The warm-up period starts with this procedure ($t \text{ [sec]} = \text{wall thickness [mm]} \times 10$).
10. Once the warm-up period has finished $t \text{ [s]}$, the carrier is retracted, the heating tool quickly removed and the pipes are pressed together again. (conversion time)
11. The pipes are pressed together by applying the required welding pressure (see table on the machine) and cool under pressure.
12. The welded joint can then be unclamped - the welding procedure is complete.

(PE-HD) MINI - VR. MAXI							
DN	s [mm]	T [°C]	Welding pressure F [N]	Bead height [mm]	Heating time t [sec]	Conversion time [sec]	Cooling time [min]
40	3,0	220	5	0,5	30	3	4
50	3,0	220	7	0,5	30	3	4
56	3,0	220	7	0,5	30	3	4
63	3,0	220	8	0,5	30	3	4
70	3,0	220	10	0,5	30	3	4
90	3,5	200	14	0,5	35	4	5
100	4,3	219	21	0,5	42	5	6
125	4,9	218	27	1,0	48	5	6
150	6,2	2,17	45	1,0	62	6	9
200	6,2	217	57	1,0	62	6	9
250	7,8	216	88	1,5	97	7	13
300	9,8	214	140	1,5	97	7	13
200 (SDR26)	7,7	214	70	1,5	77	6	11
250 (SDR26)	9,6	214	109	1,5	96	7	13
300 (SDR26)	12,1	211	173	2,0	121	8	16

Table 3: Heated-tool butt welding specifications.

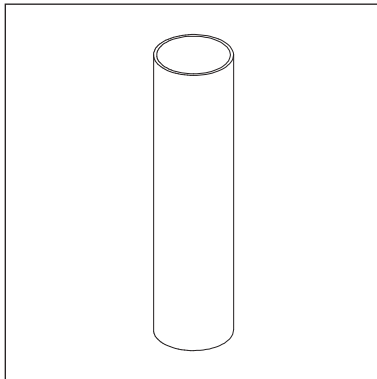

Pos 3.1 Siaqua pipelines

Application

The HDPE drain pipes and fittings are suitable for both siphonic drainage systems as well as for conventional partially filled gravity drainage systems. The range includes pipes and fittings made of HDPE in sizes from DN 40 to DN 300.

Thanks to the superior material quality of HDPE, the drain pipes have proved extremely effective for use in industrial and laboratory drainage as well as for domestic and private property drainage and plumbing.

The HDPE pipes can be sealed using gravity welding or electro-fusion sockets to ensure a permanently airtight and highly resistant joint.

Technical data

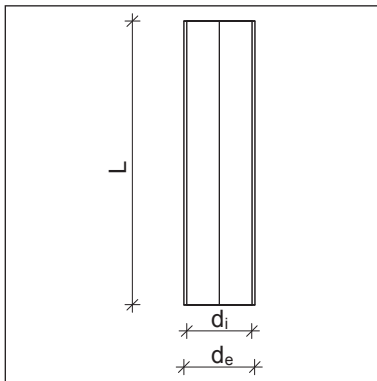

Material:	High-Density Polyethylene (HDPE), black
<u>Physical properties:</u>	
Retention of internal pressure:	80° C, 3.9 MPa, min. 165 h
Short-term exposure:	95° C (hot water)
Constant operating pressure:	+4.0 bar for de 40 to 160 mm (SDR 26) +3.2 bar for de 200 to 315 mm (SDR 33)
Max. negative pressure:	-0.8 bar for de 40 to 250 mm -0.45 bar for de 315 mm (SDR 33)
Thermal expansion coefficient:	0.2 mm/m °C
UV resistance:	with carbon percentage of 2.0 - 2.5 %
Fire behaviour:	DIN 4102, B2
<u>Chemical resistance:</u>	HDPE is resistant to aggressive chemicals. More detailed information can be found in DIN 8075.
<u>Labelled with:</u>	Siaqua PE, nominal width, year of manufacture, material, register number, fire class: B2

Approvals

According to an inspection conducted by the Materialprüfanstalt Darmstadt (MPA DA, reg. no. K 080/07), the HDPE drain pipe system conforms with the technical guidelines outlined in DIN EN 1519-1 in connection with DIN 19535-10.

Position number	Type	de [mm]	di [mm]	s [mm]	L [mm]	G [kg/m]	H ₂ O filled [Kg/m]	Pack. [m]	Art.No.
3.1.1	DN 40	40	34,0	3,0	5000	0,36	1,26	5	600400
3.1.2	DN 50	50	44,0	3,0	5000	0,45	1,96	5	600401
3.1.3	DN 56	56	50,0	3,0	5000	0,51	2,46	5	600402
3.1.4	DN 63	63	57,0	3,0	5000	0,57	3,12	5	600403
3.1.5	DN 70	75	69,0	3,0	5000	0,69	4,42	5	600404
3.1.6	DN 90	90	83,0	3,5	5000	0,96	6,36	5	600405
3.1.7	DN 100	110	101,4	4,3	5000	1,44	9,50	5	600406
3.1.8	DN 125	125	115,2	4,9	5000	1,87	12,27	5	600407
3.1.9	DN 150	160	147,6	6,2	5000	3,03	20,11	5	600408
3.1.10	DN 200	200	187,6	6,2	5000	3,82	31,42	5	600409
3.1.11	DN 250	250	234,4	7,8	5000	6,00	49,09	5	600410
3.1.12	DN 300	315	295,4	9,8	5000	6,51	77,93	5	600411
PE-HDV drain pipe - reinforced SDR 26									
3.1.13	DN 200	200	184,6	7,7	5000	4,70	31,46	5	600690
3.1.14	DN 250	250	230,8	9,6	5000	7,32	49,16	5	600691
3.1.15	DN 300	315	290,8	12,1	5000	11,62	78,04	5	600692

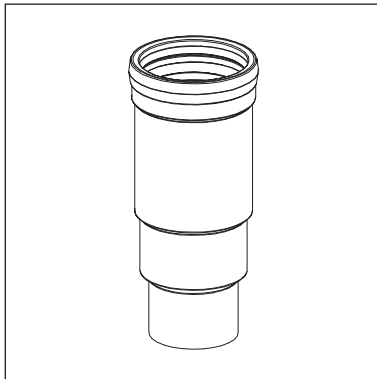

Pos 3.2.1.1 SDA socket SM

Application

Joint between the SDA roof drain and the pipeline system

Scope of delivery

SDA socket (SM) with integrated snap ring and BL lip seal

Installation

The socket is inserted onto the SDA basic drain fitting so that the snap ring clicks into the notch on the outlet fitting. It ensures longitudinal positive-locking from the basic drain fitting to the pipeline system.

The HDPE pipe system is connected with an electro-fusion socket (pos. 3.3).

Technical data

Material: Socket: PE-HD
 Snap ring: PP
 BL-Lip seal: SBR/EPDM

Article number

Position number	Art.No.
3.2.1.1	601036

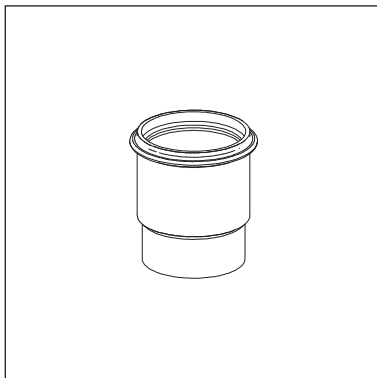

Pos 3.2.1.2 PE-HD socket

Application

Joint fitting to connect the Siaqua gravity roof drains to the rest of the PE-HD pipe-work.

Installation

The socket is inserted from underneath onto the roof drain. To prevent the socket from slipping from the roof drain fitting, the single connection pipe must be securely fastened using a single joint (pos. 4.1). The HDPE pipe system is connected with an electro-fusion socket (pos. 3.3).

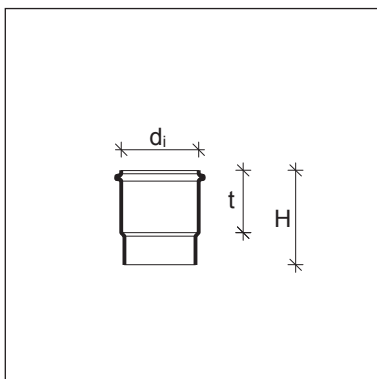

Position number	DN	d ₁ [mm]	t [mm]	H [mm]	G [kg]	Pack.	Art. No.
3.2.1.2.1	40	41	50	85	0,04	1	600694
3.2.1.2.2	50	51	50	85	0,06	1	600601
3.2.1.2.3	56	57	52	85	0,05	1	600602
3.2.1.2.4	63	64	52	85	0,07	1	600603
3.2.1.2.5	70	76	66	100	0,08	1	600604
3.2.1.2.6	90	91	70	105	0,13	1	600605
3.2.1.2.7	100	112	70	105	0,19	1	600606
3.2.1.2.8	125	127	75	115	0,25	1	600607
3.2.1.2.9	150	162	93	140	0,42	1	600608

2015-01 Subject to technical modifications. Copyright Sikla Drain GmbH

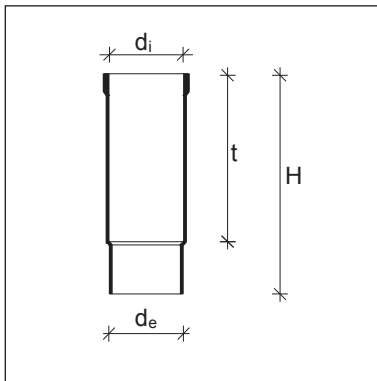
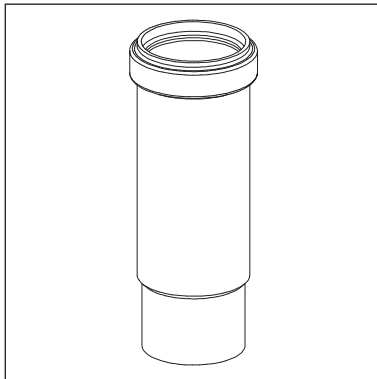

Pos 3.2.1.3 PE-HD long sleeve socket

Position number	DN	d _i [mm]	t [mm]	H [mm]	G [kg]	Pack.	Art. No.
3.2.1.3.1	40	41	170	235	0,12	1	600570
3.2.1.3.2	50	51	170	235	0,16	1	600571
3.2.1.3.3	56	57	170	235	0,16	1	600572
3.2.1.3.4	63	64	175	235	0,18	1	600573
3.2.1.3.5	70	76	179	240	0,21	1	600574
3.2.1.3.6	90	91	175	240	0,29	1	600575
3.2.1.3.7	100	112	178	255	0,43	1	600576
3.2.1.3.8	125	127	180	255	0,56	1	600577
3.2.1.3.9	150	162	190	285	0,80	1	600578
3.2.1.3.10	200	202	200	290	2,30	1	600579
3.2.1.3.11	250	253	250	360	4,10	1	600580
3.2.1.3.12	300	318	250	350	6,55	1	600581

Insertion depths of long sleeve socket

50 [mm] protection against falling out
 Pipe length: 10,0 [m]
 Temperature range: -30 [°C] bis +30 [°C]

Installation temp.	Insertion depth	Installation temp.	Insertion depth
-5 [°C]	100 [mm]	12 [°C]	134 [mm]
-4 [°C]	102 [mm]	13 [°C]	136 [mm]
-3 [°C]	104 [mm]	14 [°C]	138 [mm]
-2 [°C]	106 [mm]	15 [°C]	140 [mm]
-1 [°C]	108 [mm]	16 [°C]	142 [mm]
0 [°C]	110 [mm]	17 [°C]	144 [mm]
1 [°C]	112 [mm]	18 [°C]	146 [mm]
2 [°C]	114 [mm]	19 [°C]	148 [mm]
3 [°C]	116 [mm]	20 [°C]	150 [mm]
4 [°C]	118 [mm]	21 [°C]	152 [mm]
5 [°C]	120 [mm]	22 [°C]	154 [mm]
6 [°C]	122 [mm]	23 [°C]	156 [mm]
7 [°C]	124 [mm]	24 [°C]	158 [mm]
8 [°C]	126 [mm]	25 [°C]	160 [mm]
9 [°C]	128 [mm]	26 [°C]	162 [mm]
10 [°C]	130 [mm]	27 [°C]	164 [mm]
11 [°C]	132 [mm]	28 [°C]	166 [mm]

Table 4: Insertion depths of long sleeve sockets

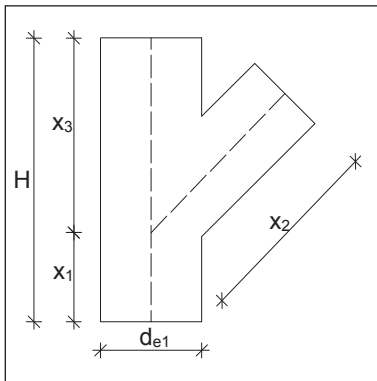
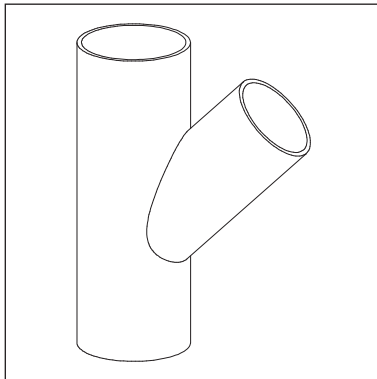

Pos 3.2.2 PE-HD Tees

Position number	DN ₁ /DN ₂	X ₁ [mm]	X ₂ = X ₃ [mm]	H [mm]	G [kg]	Pack.	Art. No.
3.2.2.1.1	40/40	45	90	135	0,07	1	600510
3.2.2.2.1	50/40	55	110	165	0,10	1	600511
3.2.2.2.2	50/50	55	110	165	0,11	1	600512
3.2.2.3.2	56/50	60	120	180	0,13	1	600513
3.2.2.3.3	56/56	60	120	180	0,13	1	600514
3.2.2.4.1	63/40	65	130	195	0,14	1	600515
3.2.2.4.2	63/50	65	130	195	0,15	1	600516
3.2.2.4.3	63/56	65	130	195	0,15	1	600517
3.2.2.4.4	63/63	65	130	195	0,16	1	600518
3.2.2.5.2	70/50	70	140	210	0,19	1	600519
3.2.2.5.3	70/56	70	140	210	0,19	1	600520
3.2.2.5.4	70/63	70	140	210	0,19	1	600521
3.2.2.5.5	70/70	70	140	210	0,21	1	600522
3.2.2.6.2	90/50	80	160	240	0,28	1	600523
3.2.2.6.4	90/63	80	160	240	0,28	1	600524
3.2.2.6.5	90/70	80	160	240	0,29	1	600525
3.2.2.6.6	90/90	80	160	240	0,32	1	600526
3.2.2.7.2	100/50	90	180	270	0,45	1	600527
3.2.2.7.3	100/56	90	180	270	0,46	1	600528
3.2.2.7.4	100/63	90	180	270	0,45	1	600529
3.2.2.7.5	100/70	90	180	270	0,45	1	600530
3.2.2.7.6	100/90	90	180	270	0,50	1	600531
3.2.2.7.7	100/100	90	180	270	0,53	1	600532
3.2.2.8.2	125/50	100	200	300	0,61	1	600869
3.2.2.8.4	125/63	100	200	300	0,65	1	600533
3.2.2.8.5	125/70	100	200	300	0,65	1	600534
3.2.2.8.6	125/90	100	200	300	0,66	1	600870
3.2.2.8.7	125/100	100	200	300	0,73	1	600535
3.2.2.8.8	125/125	100	200	300	0,76	1	600536
3.2.2.9.7	150/100	125	250	375	1,30	1	600537
3.2.2.9.8	150/125	125	250	375	1,38	1	600538
3.2.2.9.9	150/150	125	250	375	1,52	1	600539
3.2.2.10.7	200/100	180	360	540	2,34	1	600540
3.2.2.10.8	200/125	180	360	540	1,84	1	600541
3.2.2.10.9	200/150	180	360	540	2,33	1	600542
3.2.2.10.10	200/200	180	360	540	2,98	1	600543
3.2.2.11.7	250/100	220	440	660	4,55	1	600544
3.2.2.11.8	250/125	220	440	660	4,45	1	600545
3.2.2.11.9	250/150	220	440	660	4,80	1	600546
3.2.2.11.10	250/200	220	440	660	4,80	1	600547
3.2.2.11.11	250/250	220	440	660	5,38	1	600548
3.2.2.12.7	300/100	280	560	840	8,60	1	600549
3.2.2.12.8	300/125	280	560	840	8,80	1	600550
3.2.2.12.9	300/150	280	560	840	9,01	1	600551
3.2.2.12.10	300/200	280	560	840	9,32	1	600552
3.2.2.12.11	300/250	280	560	840	9,30	1	600553
3.2.2.12.12	300/300	280	560	840	9,38	1	600554

2015-01 Subject to technical modifications. Copyright Sikla Drain GmbH

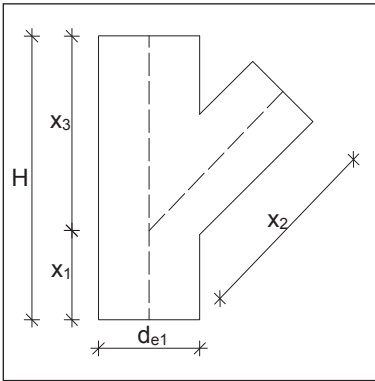
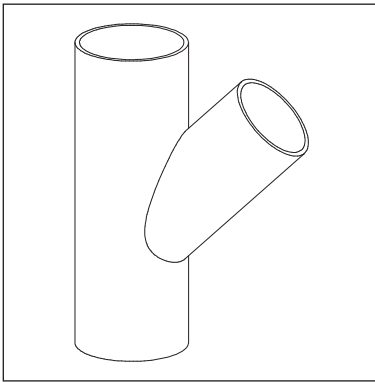

Pos 3.2.2 PE-HDV tees - reinforced SDR 26

Position number	DN ₁ /DN ₂	x ₁ [mm]	x ₂ = x ₃ [mm]	H [mm]	G [kg]	Pack.	Art. No.
3.2.2.13.7	200/100	180	360	540	2,34	1	600955
3.2.2.13.8	200/125	180	360	540	1,84	1	600956
3.2.2.13.9	200/150	180	360	540	2,33	1	600957
3.2.2.13.13	200/200	180	360	540	2,33	1	600958
3.2.2.14.7	250/100	220	440	660	4,55	1	600959
3.2.2.14.8	250/125	220	440	660	4,65	1	600960
3.2.2.14.9	250/150	220	440	660	4,80	1	600961
3.2.2.14.13	250/200	220	440	660	4,77	1	600962
3.2.2.14.14	250/250	220	440	660	5,38	1	600963
3.2.2.15.7	300/100	280	560	840	5,45	1	600964
3.2.2.15.8	300/125	280	560	840	6,50	1	600965
3.2.2.15.9	300/150	280	560	840	9,01	1	600966
3.2.2.15.13	300/200	280	560	840	9,32	1	600967
3.2.2.15.14	300/250	280	560	840	9,30	1	600968
3.2.2.15.15	300/300	280	560	840	9,38	1	600969

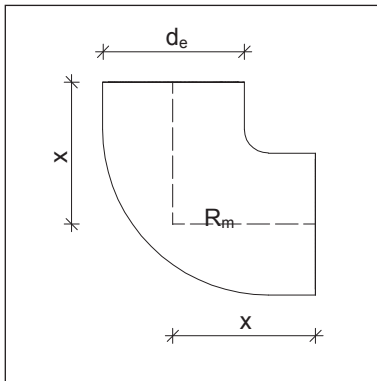
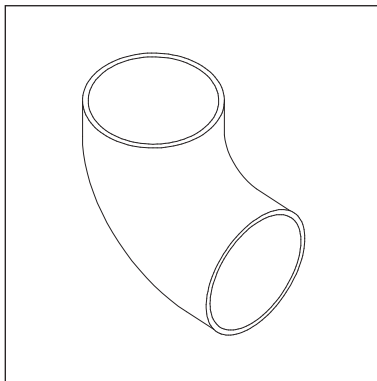
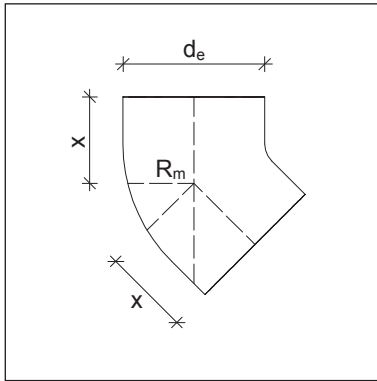
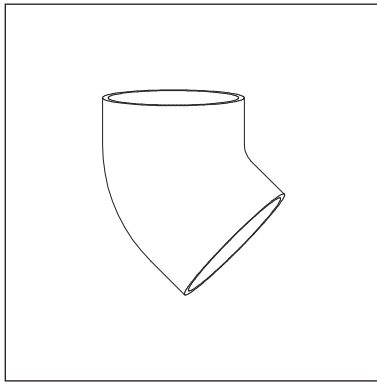

Pos 3.2.3 Siaqua elbows

Position number	Type	d _e [mm]	x [mm]	R _m [mm]	G [kg]	Pack.	Art. No.
PE-HD elbow 15°							
3.2.3.1.7	DN 100	110	45	80	0,15	1	600470
3.2.3.1.8	DN 125	125	150	—	0,23	1	600471
3.2.3.1.9	DN 150	160	150	—	0,46	1	600472
3.2.3.1.9	DN 200	200	150	—	0,83	1	600473
PE-HD elbow 30°							
3.2.3.2.7	DN 100	110	55	80	0,17	1	600474
3.2.3.2.8	DN 125	125	60	90	0,24	1	600475
3.2.3.2.9	DN 150	160	80	140	0,46	1	600476
3.2.3.2.10	DN 200	200	115	225	0,83	1	600477
3.2.3.2.11	DN 250	250	120	260	1,37	1	600478
3.2.3.2.12	DN 300	315	145	260	2,16	1	600479
PE-HD elbow 45°							
3.2.3.3.1	DN 40	40	40	30	0,03	1	600480
3.2.3.3.2	DN 50	50	45	50	0,04	1	600481
3.2.3.3.3	DN 56	56	45	50	0,05	1	600482
3.2.3.3.4	DN 63	63	50	50	0,06	1	600483
3.2.3.3.5	DN 70	75	50	50	0,08	1	600484
3.2.3.3.6	DN 90	90	55	70	0,11	1	600485
3.2.3.3.7	DN 100	110	60	80	0,17	1	600486
3.2.3.3.8	DN 125	125	65	90	0,24	1	600487
3.2.3.3.9	DN 150	160	100	140	0,67	1	600488
3.2.3.3.10	DN 200	200	160	200	1,16	1	600489
3.2.3.3.11	DN 250	250	190	250	2,16	1	600490
3.2.3.3.12	DN 300	315	205	277	3,35	1	600491
PE-HDV elbow 45° - reinforced SDR 26							
3.2.3.3.13	DN 200	200	170	—	0,83	1	600932
3.2.3.3.14	DN 250	250	204	—	2,60	1	600933
3.2.3.3.15	DN 300	315	244	—	4,96	1	600934
PE-HD elbow 88,5°							
3.2.3.4.1	DN 40	40	60	30	0,04	1	600492
3.2.3.4.2	DN 50	50	70	50	0,06	1	600493
3.2.3.4.3	DN 56	56	75	50	0,07	1	600494
3.2.3.4.4	DN 63	63	80	50	0,10	1	600495
3.2.3.4.5	DN 70	75	75	50	0,11	1	600496
3.2.3.4.6	DN 90	90	100	70	0,13	1	600497
3.2.3.4.7	DN 100	110	110	80	0,25	1	600498
3.2.3.4.8	DN 125	125	125	90	0,42	1	600499
3.2.3.4.9	DN 150	160	180	140	0,95	1	600500
3.2.3.4.10	DN 200	200	275	200	2,10	1	600501
3.2.3.4.11	DN 250	250	335	250	5,00	1	600693
3.2.3.4.12	DN 300	315	365	277	7,00	1	600503
PE-HDV elbow 88,5° - reinforced SDR 26							
3.2.3.4.13	DN 200	200	410	—	1,57	1	600937
3.2.3.4.14	DN 250	250	506	—	3,65	1	600938
3.2.3.4.15	DN 300	315	623	—	6,47	1	600939

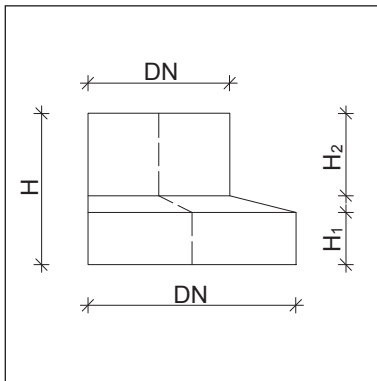
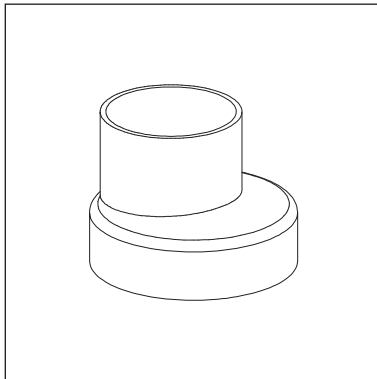

Pos 3.2.4 PE-HD reducer

Position number	DN	H ₁ [mm]	H ₂ [mm]	H [mm]	G [kg]	Pack.	Art. No.
3.2.4.2.1	50/40	35	37	80	0,03	1	600435
3.2.4.3.1	56/40	35	37	80	0,04	1	600436
3.2.4.3.2	56/50	35	37	80	0,04	1	600437
3.2.4.4.1	63/40	35	37	80	0,04	1	600438
3.2.4.4.2	63/50	35	37	80	0,04	1	600439
3.2.4.4.3	63/56	35	37	80	0,04	1	600440
3.2.4.5.1	70/40	35	37	80	0,06	1	600441
3.2.4.5.2	70/50	35	37	80	0,05	1	600442
3.2.4.5.3	70/56	35	37	80	0,04	1	600443
3.2.4.5.4	70/63	35	37	80	0,05	1	600444
3.2.4.6.2	90/50	31	34	80	0,06	1	600445
3.2.4.6.3	90/56	31	36	80	0,06	1	600446
3.2.4.6.4	90/63	31	38	80	0,07	1	600447
3.2.4.6.5	90/70	31	43	80	0,07	1	600448
3.2.4.7.2	100/50	31	34	80	0,15	1	600449
3.2.4.7.3	100/56	31	35	80	0,14	1	600450
3.2.4.7.4	100/63	31	36	80	0,13	1	600451
3.2.4.7.5	100/70	31	38	80	0,12	1	600452
3.2.4.7.6	100/90	32	41	80	0,09	1	600453
3.2.4.8.5	125/70	35	31	80	0,12	1	600454
3.2.4.8.6	125/90	35	32	80	0,15	1	600455
3.2.4.8.7	125/100	36	36	80	0,13	1	600456
3.2.4.9.7	150/100	35	37	80	0,22	1	600457
3.2.4.9.8	150/125	35	37	80	0,22	1	600458
PE-HDV reducer - reinforced SDR 26							
3.2.4.13.7	200/100	110	50	160	0,77	1	600923
3.2.4.13.8	200/125	110	70	180	0,80	1	600924
3.2.4.13.9	200/150	110	90	200	1,17	1	600925
3.2.4.14.9	250/150	130	90	220	1,50	1	600926
5.2.4.14.13	250/200	130	110	240	1,64	1	600927
5.2.4.15.13	300/200	150	130	280	3,50	1	600928
5.2.4.15.14	300/250	150	130	280	3,50	1	600929
PE-HD reducer - long							
5.2.4.10.7	200/100	110	60	325	0,77	1	600462
5.2.4.10.8	200/125	110	70	310	0,80	1	600463
5.2.4.10.9	200/150	110	90	270	1,17	1	600464
5.2.4.11.10	250/200	130	110	325	1,64	1	600465
5.2.4.12.11	300/250	150	130	395	3,51	1	600466

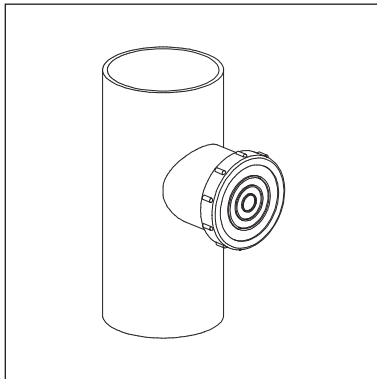

Pos 3.2.5 PE-HD cleaning pipe 90°

Position number	DN	x ₁ [mm]	x ₃ [mm]	H [mm]	G [kg]	Pack.	Art. No.
3.2.5.5	70/70	105	70	175	0,22	1	600560
3.2.5.6	90/90	120	80	200	0,33	1	600561
3.2.5.7	100/100	135	90	225	0,53	1	600562
3.2.5.8	125/100	150	100	250	0,69	1	600563
3.2.5.9	150/100	210	140	350	1,21	1	600564
3.2.5.10	200/100	180	180	360	1,61	1	600565
3.2.5.11	250/100	220	220	440	2,85	1	600566
3.2.5.12	300/100	280	280	560	5,70	1	600567

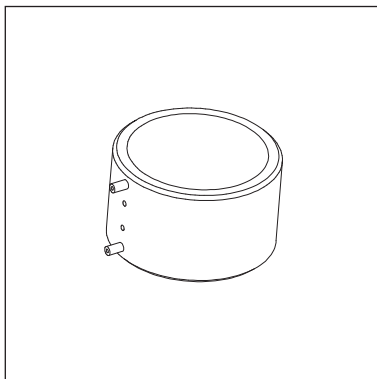
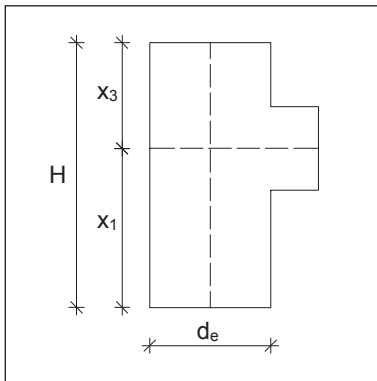

Pos 3.3 Siaqua electro-fusion socket

Application

To weld the Siaqua pipe system.

Installation

Please observe the handling instructions and guidelines for electro-welding connections (page 45).

Please also observe the operating instructions for socket welders.

Article numbers

Positionnumber	Type	Art.No.
3.3.1	DN 40	600585
3.3.2	DN 50	600586
3.3.3	DN 56	600587
3.3.4	DN 63	600588
3.3.5	DN 70	600589
3.3.6	DN 90	600590
3.3.7	DN 100	600591
3.3.8	DN 125	600592
3.3.9	DN 150	600593
3.3.10	DN 200	600970
3.3.11	DN 250	600971
3.3.12	DN 300	600972

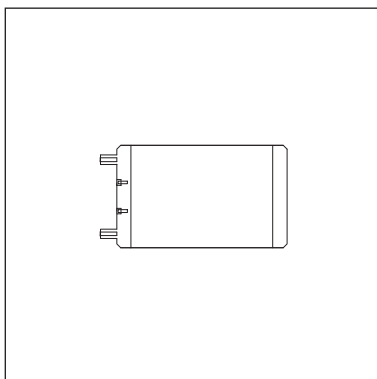

Accessories

Socket welder for PE-HD electro-fusion sockets DN40 to DN300

Butt-welding equipments for PE-HD pipes

Type [mm]	
DN 40 - 150	on request
DN 70 - 250	on request

Pipe cutter for PE-HD pipes

Type [mm]	G [kg]	Pack.	Art.No.
0 - 63	0,60	1	416713
50 - 140	1,38	1	416722
100 - 150	1,64	1	416731
180 - 300	7,00	1	416740

Processing tools

Type [mm]	G [kg]	Pack.	Art.No.
Wachs Signierkreide	0,02	12	600898
Kreidefallstift 12mm	0,03	1	600899
Rohrschaber für PE	0,25	1	600901
PE-Reiniger 0,7 Liter	0,68	1	600902

Pos. 4 Baukörperbefestigung

Pos. 4.1 Single Joint

Single joint, trapezoidal sheet metal	(Pos 4.1.1)	page 60
Single joint, concrete	(Pos 4.1.2)	page 61

Pos. 4.2 structural joint page 62

Trapezoidal sheet metal joint	(Pos 4.2.1)	page 63
Trapezoidal sheet metal joint, cross beam	(Pos 4.2.2)	page 63
Concrete ceiling joint	(Pos 4.2.3)	page 65
Twin-wall ceiling joint	(Pos 4.2.4)	page 65
Threaded rod extension	(Pos 4.2.5)	page 65
Concrete wall joint, angle bracket 300/200	(Pos 4.2.6)	page 66
Concrete wall joint. Angle bracket 550/300	(Pos 4.2.7)	page 66
Steel beam joint	(Pos 4.2.8)	page 67
Steel beam joint, double-sided	(Pos 4.2.9)	page 68
Steel beam joint, elevated	(Pos 4.2.10)	page 69
Steel beam joint, elevated, double-sided	(Pos 4.2.11)	page 69

Pos. 4.3 Structural fixed points

Structural fixed point. steel	(Pos 4.3.1)	page 70
Structural fixed point, concrete	(Pos 4.3.2)	page 70

Pos. 4.4 Down pipe joint

Down pipe joint, steel type I (on flange)	(Pos 4.4.1)	page 72
Down pipe joint, steel type II (between flanges)	(Pos 4.4.2)	page 73
Down pipe joint, concrete	(Pos 4.4.3)	page 73

Pos. 4.5 Down pipe fixed point

Down pipe fixed point, steel type I (on flange)	(Pos 4.5.1)	page 75
Down pipe fixed point, steel type II (between flanges)	(Pos 4.5.2)	page 76
Down pipe fixed point, concrete	(Pos 4.5.3)	page 76

Pos 4.6 Customised constructions (Pos 4.6) page 77

General

The structural fixtures are used to connect the supporting rail and pipelines to the building structure.

- ◆ Single joints (pos. 4.1) are used with pipe fittings of between 0.8 m and 3.0 m.
- ◆ Structural joints (pos. 4.2) connect the building structure to the supporting rail and support the weight load.
- ◆ Fixed structural points (pos. 4.3) hold the system in position and support the horizontal load.
- ◆ With the down pipe joints (pos. 4.4), the down pipes are fastened to the building structure without a supporting rail.
- ◆ Down pipe fixed points (pos. 4.5) are used to support the loads from the down pipes.
- ◆ Customised constructions (pos. 4.6) are used when standard components are not suitable for structural reasons.

The end points of the supporting rails should be fastened directly to the building structure where possible.

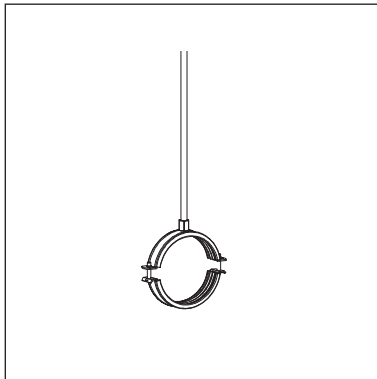

Pos 4.1 Siaqua single joints

Application

To fasten pipes with lengths between 0.8 m and 3.0 m.

Arrangement

The fastening distance should be selected according to the table below:

Type	DN	40	50	56	63	70	90	100	125	150	200	250	300
Pipe clip distance [m]		0,8	0,8	0,8	0,8	0,8	0,9	1,1	1,2	1,6	2,0	2,0	2,0

Table 5: permissible fastening distances for Siaqua single joints

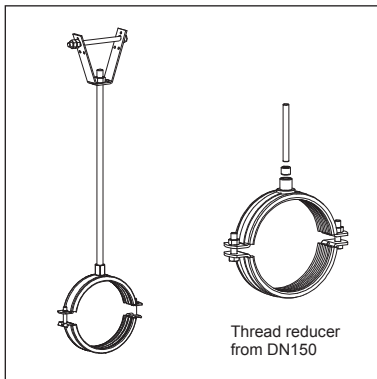

Pos 4.1.1 Siaqua single joint, trapezoidal sheet metal

Scope of delivery

2G threaded pipe clip, suitable for sizes 40 to 150; Stabil D3G pipe clip incl. thread M16/10 reducer suitable for sizes 200 to 300; M10 threaded rod; Siaqua trapezoidal suspended fitting incl. M8x110 hexagonal head screw and M8 nuts

Installation

Install trapezoidal suspended fitting using hexagonal head screw, nut and counter-nut. Screw threaded rod into trapezoidal suspended fitting. Screw pipe clip onto threaded rod. Use thread reducer from sizes of DN 150.

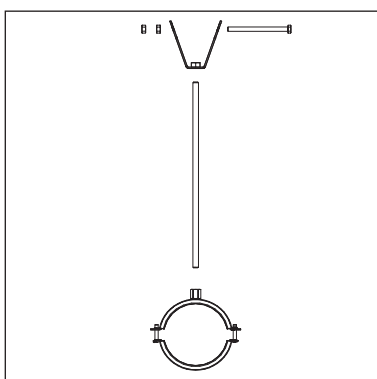
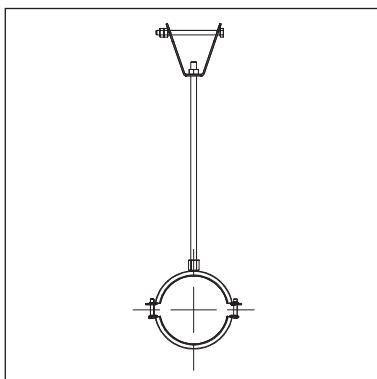

Article numbers

Position number	Type	Art.No.
4.1.1.1	DN 40	602900
4.1.1.2	DN 50	602910
4.1.1.3	DN 56	602920
4.1.1.4	DN 63	602930
4.1.1.5	DN 70	602940
4.1.1.6	DN 90	602950
4.1.1.7	DN 100	602960
4.1.1.8	DN 125	602970
4.1.1.9	DN 150	602980
4.1.1.10	DN 200	602990
4.1.1.11	DN 250	603000
4.1.1.12	DN 300	603010

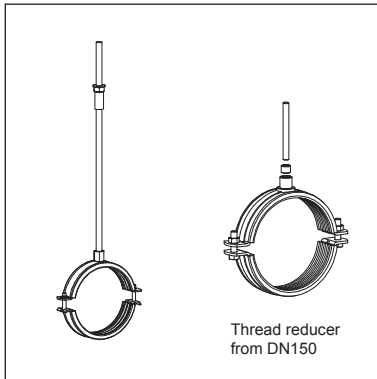

Pos 4.1.2 Siaqua single joint, concrete

Scope of delivery

2G threaded pipe clip, suitable for sizes 40 to 150; Stabil D3G pipe clip incl. thread M16/10 reducer suitable for sizes 200 to 300; M10 threaded rod; M10 extension socket; M10x10 wedge anchor

Installation

Install the wedge anchor in accordance with the installation instructions. Connect the threaded rod to the wedge anchor using the extension socket. Screw pipe clip onto the threaded rod. Use thread reducer from sizes of DN 150.

Article numbers

Position number	Type	Art.No.
4.1.2.1	DN 40	603020
4.1.2.2	DN 50	603030
4.1.2.3	DN 56	603040
4.1.2.4	DN 63	603050
4.1.2.5	DN 70	603060
4.1.2.6	DN 90	603070
4.1.2.7	DN 100	603080
4.1.2.8	DN 125	603090
4.1.2.9	DN 150	603100
4.1.2.10	DN 200	603110
4.1.2.11	DN 250	603120
4.1.2.12	DN 300	603130

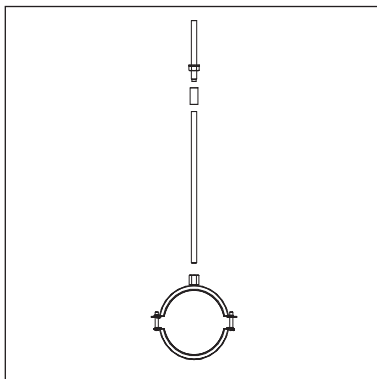
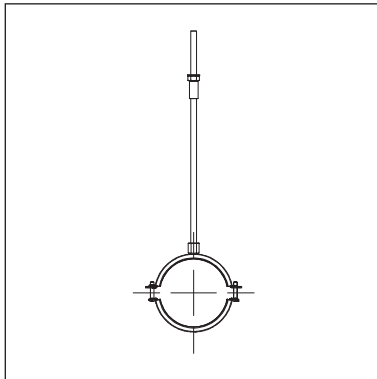

Pos 4.2 Siaqua structural joint

Fastening of supporting rail (pos. 2.1) to structure in maximum centres of:

DN	≤ 100	125	150	200	250	300
Type I (31)	3,0 [m]	2,8 [m]	2,4 [m]	1,5 [m]	—	—
Type II (41)	3,0 [m]	3,0 [m]	3,0 [m]	2,3 [m]	1,2 [m]	—
Type III (52)	3,0 [m]	3,0 [m]	3,0 [m]	3,0 [m]	2,1 [m]	1,1 [m]

Tabelle 1: Permissible fastening distances for Siaqua supporting rails

It is important to observe the permissible suspended load from the trapezoidal sheet metal when attaching to the trapezoidal sheet metal.

Fastening of supporting rail (pos. 2.1) to trapezoidal sheet metal in max. centres of:

Table 5 contains the permissible distances between the brackets for the supporting rail on trapezoidal sheet metal and depend on the permissible trapezoidal sheet metal load and the pipe cross-section in metres.

A differentiation is made between single joints and cross beams.

DN	Permissible trapezoidal metal sheet load																							
	10 [kg/m ²] Suspension [m]		15 [kg/m ²] Suspension [m]		20 [kg/m ²] Suspension [m]		25 [kg/m ²] Suspension [m]		30 [kg/m ²] Suspension [m]		35 [kg/m ²] Suspension [m]		40 [kg/m ²] Suspension [m]											
	single Pos 4.2.1	cross beam Pos.4.2.2	single Pos 4.2.1	cross beam Pos.4.2.2	single Pos 4.2.1	cross beam Pos.4.2.2	single Pos 4.2.1	cross beam Pos.4.2.2	single Pos 4.2.1	cross beam Pos.4.2.2	single Pos 4.2.1	cross beam Pos.4.2.2	single Pos 4.2.1	cross beam Pos.4.2.2										
40	2,5	3,0	3,0	3,0	3,0	3,0	3,0	3,0	3,0	3,0	3,0	3,0	3,0	3,0										
50	1,9		2,8																					
56	1,7		2,6																					
63	1,5		2,3																					
70	1,2	2,5	1,9	3,0	2,5	3,0	3,0	3,0	3,0	3,0	3,0	3,0	3,0	3,0										
90	1,0	2,0	1,5		2,0																			
100	—	—	—		—										1,5	—	—	—	—	—	—	—	—	—
125															1,2									
150				1,2		1,2	1,7	1,0	2,1	1,2	2,5	1,5	1,7											
200				—		—	—	—	1,0	—	1,3	—	1,6	—	1,9									
250	—	—	—	—	—	—	—	—	1,1	—	1,2	—	1,4											
300	—	—	—	—	—	—	—	—	—	—	—	—	—											

Table 6: Permissible fastening distances on the trapezoidal sheet metal

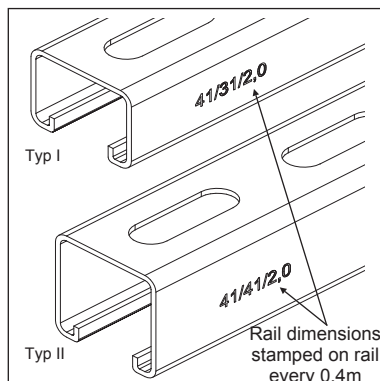

Caution

- ◆ Observe the permissible fastening distances of the supporting rails! (Tabelle 1)
- ◆ Observe specifications on the project-specific pipework diagrams

Note

- ▶ Rail dimensions stamped on rail every 0,4m

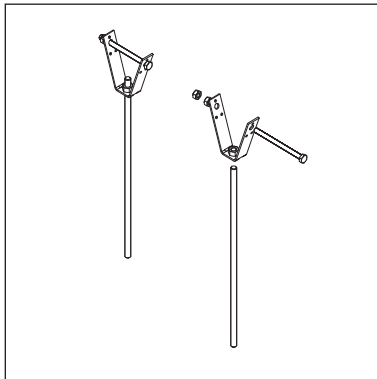

Pos 4.2.1 Siaqua trapezoidal sheet metal joint

Application

To fasten the Siaqua supporting rail on the trapezoidal sheet metal.

Scope of delivery

Threaded rod M10;
Siaqua trapezoidal suspended fitting incl. M8x110 hexagonal head screw and 2x M8 nuts

Installation

Install trapezoidal suspended fitting using hexagonal head screw, nut and counter-nut. Screw threaded rod into trapezoidal suspended fitting.
A Siaqua suspended rail fitting (pos. 2.2) is used to connect to the supporting rail.

Article number

Position number	Art.No.
4.2.1	602105

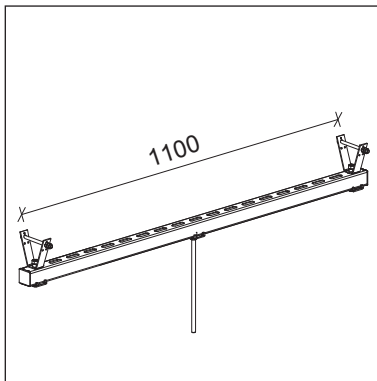

Pos 4.2.2 Siaqua trapezoidal sheet metal joint, cross beam Type I

Application

To fasten the Siaqua supporting rail on the trapezoidal sheet metal. The cross-beam is used when the load has to be applied to the trapezoidal sheet metal over two separate points due to the trapezoidal sheet metal load permitted.

Scope of delivery

Siaqua trapezoidal suspended fitting incl. M8x110 hexagonal head screw and 2x M8 nuts
2x M10/60 hexagonal head screws; 2x M10 retaining bracket;
1.2 [m] installation rail type I with cover caps; Block PBH M10; 1x M10 flange nuts;
M10 threaded rod

Installation

Screw the cross-beam trapezoidal suspended fitting loosely to the installation rail. Align the trapezoidal suspended fitting on the profiles and securely tighten. Fasten the trapezoidal suspended fitting to the trapezoidal sheet metal with hexagonal head screw, nut and counter-nut. Insert the block and the threaded rod inside the installation rail and tighten with flange nut.
A Siaqua suspended rail fitting (pos. 2.1) is used to connect to the supporting rail.

Article number

Position number	Art.No.
4.2.2	602106

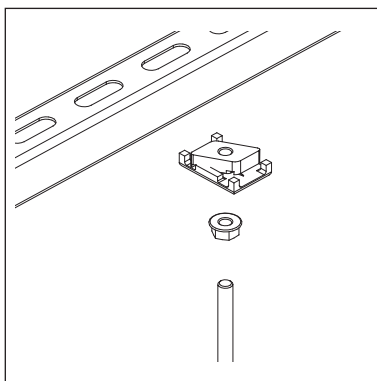
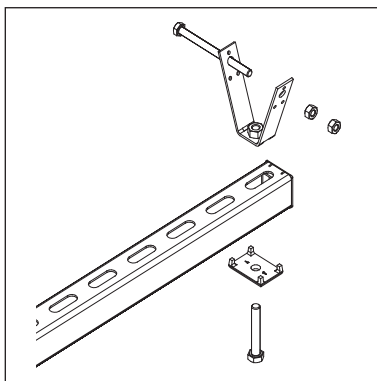

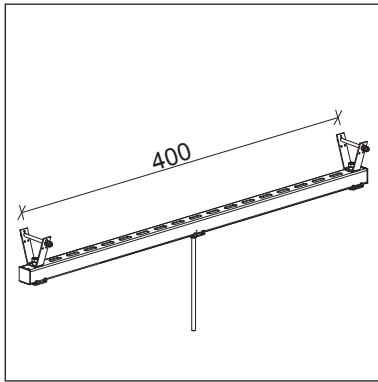

Pos 4.2.2 Siaqua trapezoidal sheet metal joint, cross beam Type II

Einsatz

To fasten the Siaqua supporting rail on the trapezoidal sheet metal. When needed cross beam is used as a replacement for single trapezoidal sheet metal joint.

Example: Pipe guiding through drilled concrete beams (see pictures A;B)

Scope of delivery

Siaqua trapezoidal suspended fitting incl. M8x110 hexagonal head screw and 2x M8 nuts 2x M10/60 hexagonal head screws; 2x M10 retaining bracket; 1.2 [m] installation rail type I with cover caps; Block PBH M10; 1x M10 flange nuts; M10 threaded rod

Installation

Screw the cross-beam trapezoidal suspended fitting loosely to the installation rail. Align the trapezoidal suspended fitting on the profiles and securely tighten.

Fasten the trapezoidal suspended fitting to the trapezoidal sheet metal with hexagonal head screw, nut and counternut.

Insert the block and the threaded rod inside the installation rail and tighten with flange nut.

A Siaqua suspended rail fitting (pos. 2.1) is used to connect to the supporting rail.

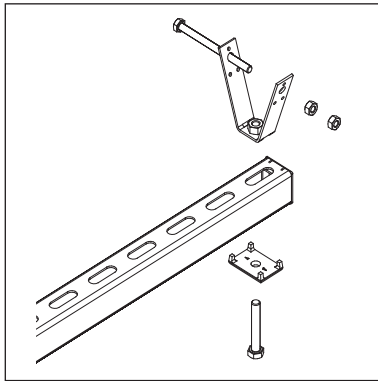

Positions- number	Art.Nr.
4.2.2	602152

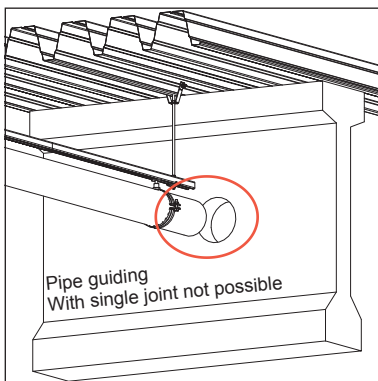
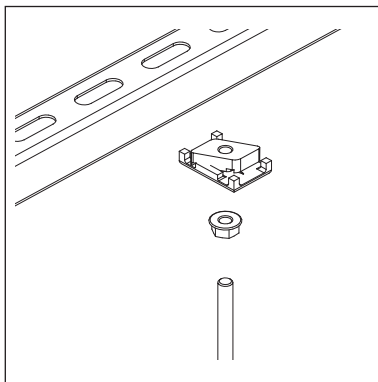

A

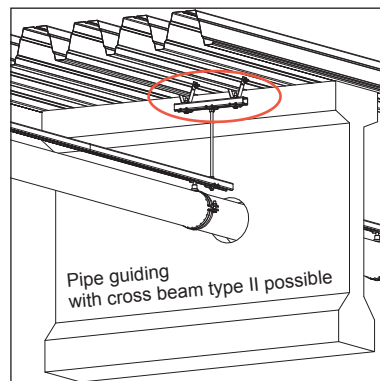

B

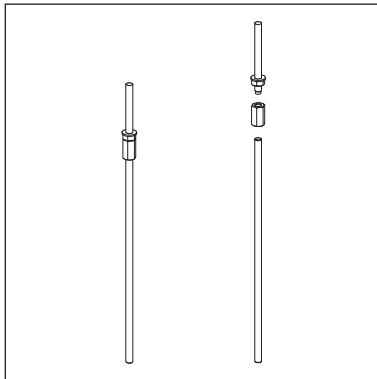

Pos 4.2.3 Siaqua concrete ceiling joint

Application

To fasten the Siaqua supporting rail on the concrete ceilings.

Scope of delivery

M10/10 wedge anchor; M10x10 extension socket; M10 threaded rod

Installation

Install the wedge anchor in accordance with the installation instructions.

Tighten the threaded rod to the wedge anchor using the extension socket. A Siaqua suspended rail fitting (pos. 2.2) is used to connect to the supporting rail.

Article number

Positions-number	Art.Nr.
4.2.3	602107

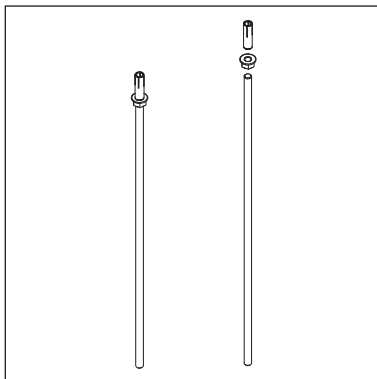

Pos. 4.2.4: Siaqua twin-wall ceiling joint

Application

To fasten the Siaqua supporting rail under twin-wall ceilings. Please observe the permissible loads of the wall plugs.

Scope of delivery

M10 cut anchor; M10 flange nut; M10 threaded rod

Installation

Attach the cut anchor. Tighten the threaded rod into the wall plugs. Counter with flange nut.

A Siaqua suspended rail fitting (pos. 2.2) is used to connect to the supporting rail.

Article number

Positions-number	Art.Nr.
4.2.4	602109

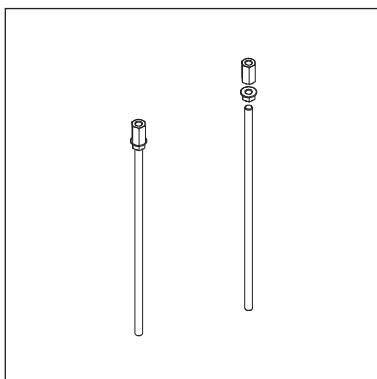

Pos. 4.2.5: Siaqua threaded rod extension

Application

To extend the threaded rods on low-suspended systems.

(Particular attention must be given here to prevent the system from swinging).

Scope of delivery

M10x30 extension socket; M10 flange nut; M10 threaded rod

Installation

Screw the extension socket onto the existing threaded rod until the centre is reached

Screw in the threaded rod.

Counter the flange nut.

A Siaqua suspended rail fitting (pos. 2.2) is used to connect to the supporting rail.

Article number

Positions-number	Art.Nr.
4.2.5	603021

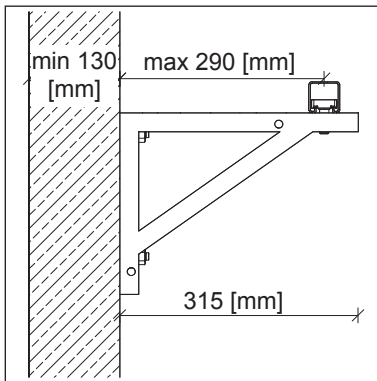

Pos 4.2.6 Siaqua concrete wall joint: angle bracket 300/200

Application

To fasten the Siaqua supporting rail to concrete walls and supports.

Arrangement

Permissible bracket distance:

- ◆ up to DN 250: 3,0 m
- ◆ DN 300: 2,5 m

Caution: Observe the permissible fastening distances of the supporting rail (page 27)!

Scope of delivery

2x M12/30 wedge anchors; 2x spacers; 300/200 angle bracket; M12x55 hook screw

Installation

Install the angle bracket using wedge anchors and spacers. Install the supporting rail using a hook screw.

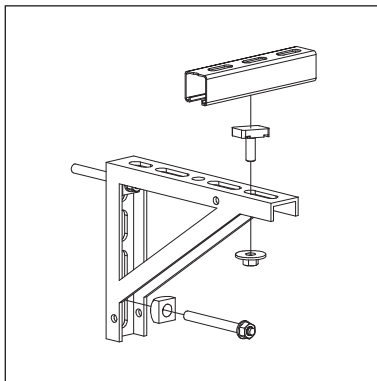

Article number

Position number	Art.No.
4.2.6	602112

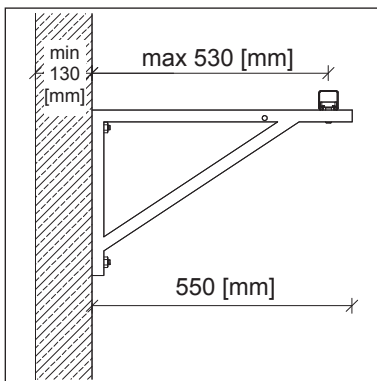

Pos. 4.2.7: Siaqua concrete ceiling joint: angle bracket 550/350

Application

To fasten the Siaqua supporting rail to concrete walls and supports.

Arrangement

Permissible bracket distance:

- ◆ up to DN 250: 3,0 m
- ◆ DN 300: 2,0 m

Caution: Observe the permissible fastening distances of the supporting rail (page 27)!

Scope of delivery

2x M12/30 wedge anchors; 2x spacers; 550/300 angle bracket; M12x55 hook screw

Installation

Install the angle bracket using wedge anchors and spacers. Install the supporting rail using a hook screw.

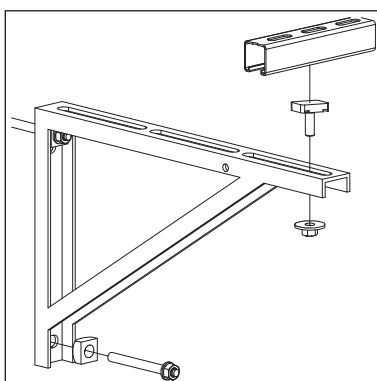

Article number

Position number	Art.No.
4.2.7	602113

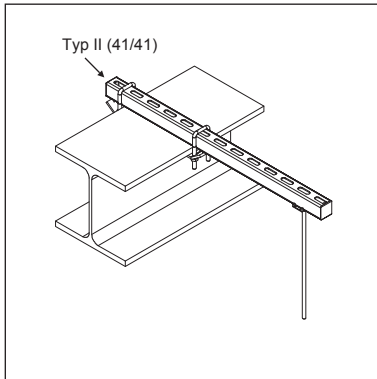

Pos 4.2.8 - 4.2.11 Siaqua steel beam joints

Application

To fasten the Siaqua supporting rails on or under steel beams.

Fastening distances

Permissible fastening distances of steel beam joint depends on the flange width ($a \geq 100$ mm) and the projection ($b \leq 600$ mm):

- ◆ up to DN150: Fastening distance 3,0 m
- ◆ from DN200 see table 7

Installation on steel beam:

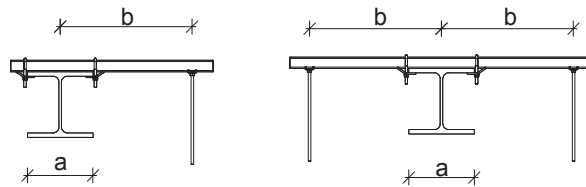

Suspended installation:

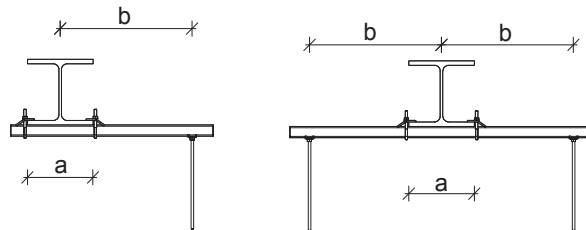

a \ b	600 [mm]	500 [mm]	400 [mm]	300 [mm]	200 [mm]
≥ 250 [mm]	DN200: 2,2 [m] DN250: 1,5 [m] DN300: 1,0 [m]	DN200: 2,8 [m] DN250: 1,9 [m] DN300: 1,2 [m]	DN200: 3,0 [m] DN250: 2,6 [m] DN300: 1,7 [m]	DN200: 3,0 [m] DN250: 3,0 [m] DN300: 2,7 [m]	
200 [mm]	DN200: 2,1 [m] DN250: 1,4 [m] DN300: 0,9 [m]	DN200: 2,7 [m] DN250: 1,8 [m] DN300: 1,2 [m]	DN200: 3,0 [m] DN250: 2,4 [m] DN300: 1,5 [m]	DN200: 3,0 [m] DN250: 3,0 [m] DN300: 2,4 [m]	DN200: 3,0 [m] DN250: 3,0 [m] DN300: 3,0 [m]
150 [mm]	DN200: 2,0 [m] DN250: 1,3 [m] DN300: 0,8 [m]	DN200: 2,5 [m] DN250: 1,7 [m] DN300: 1,1 [m]	DN200: 3,0 [m] DN250: 2,2 [m] DN300: 1,4 [m]	DN200: 3,0 [m] DN250: 3,0 [m] DN300: 2,1 [m]	
100 [mm]	DN200: 1,9 [m] DN250: 1,3 [m] DN300: 0,8 [m]	DN200: 2,4 [m] DN250: 1,6 [m] DN300: 1,0 [m]	DN200: 3,0 [m] DN250: 2,1 [m] DN300: 1,3 [m]	DN200: 3,0 [m] DN250: 2,6 [m] DN300: 1,7 [m]	DN200: 3,0 [m] DN250: 3,0 [m] DN300: 2,3 [m]

Table 7: Permissible fastening distances for Siaqua steel beam joint

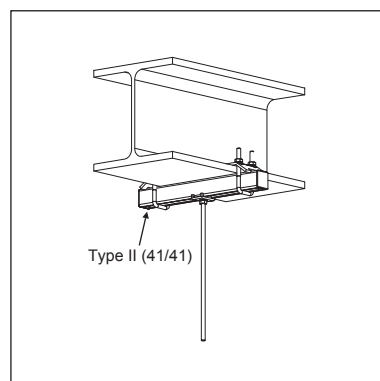
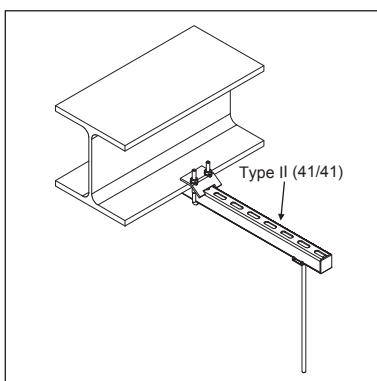

Note
When arranging the pipework in the centre underneath the steel beam, a bracket distance of 3m can be used for every pipe size

Caution
The permissible distances of the supporting rail must be observed for all pipework arrangements! (page 38)

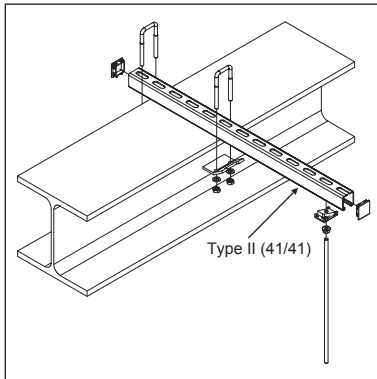

Pos 4.2.8 Siaqua steel beam joint

Application

To fasten a Siaqua supporting rail on or under steel beams. Observe the permissible fastening distances!

Scope of delivery

2x M10 clamps; 2x cover caps, type II
M10 block; M10 flange nut; M10 threaded rod
Shorten the installation rail type II to the existing material.

Installation

Fasten the installation rail using clamps on the steel beam (tightening torque: 30 [Nm]).
Click the block into the rail and align to the required distance. Screw on the threaded rod and secure with the flange nut.
A Siaqua suspended rail fitting is used to connect to the supporting rail (pos. 2.2).

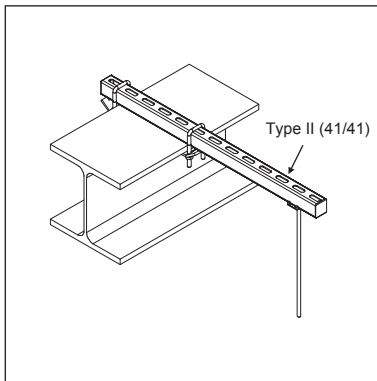

Article number

Position number	Art.No.
4.2.8	602132

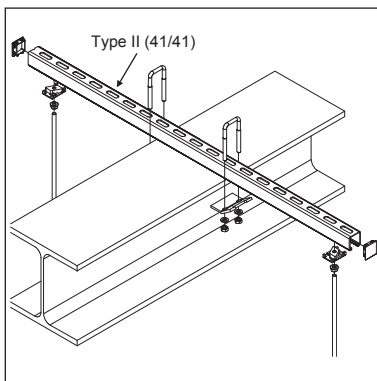

Pos 4.2.9 Siaqua steel beam joint, double-sided

Application

To fasten two Siaqua supporting rails on or under steel beams. Observe permissible fastening distances!

Scope of delivery

2x M10 clamps; 2x cover caps, Type II
2x M10 blocks; 2x M10 flange nuts; 2x M10 threaded rods Shorten installation rail to the existing material.

Installation

Fasten the installation rail using clamps on the steel beam (tightening torque: 30 [Nm]).
Click the block into the rail and align to the required distance. Screw on the threaded rod and secure with the flange nut.
A Siaqua suspended rail fitting (pos. 2.2) is used to connect to the supporting rail.

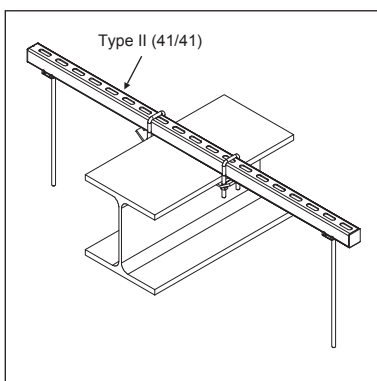

Article number

Position number	Art.No.
4.2.9	602134

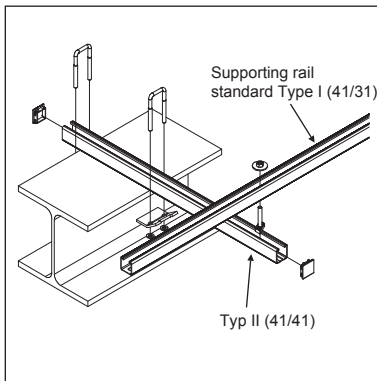

Pos 4.2.10 Siaqua elevated steel beam joint

Application

To fasten a Siaqua supporting rail on or under steel beams. Observe the permissible fastening distances!

Scope of delivery

2x M10 clamps; 2x cover caps, type II
1x hook screw (HZ) 41 M10x55
Shorten the installation rail type II to the existing material.

Installation

Fasten the installation rail using clamps on the steel beam (tightening torque: 30 [Nm]).
Position the supporting rail onto the installation rail. Fasten the installation rails using the hook screw.

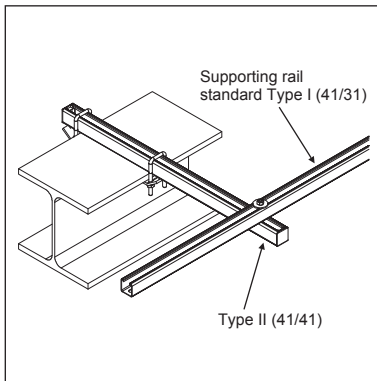

Article number

Position number	Art.No.
4.2.10	602133

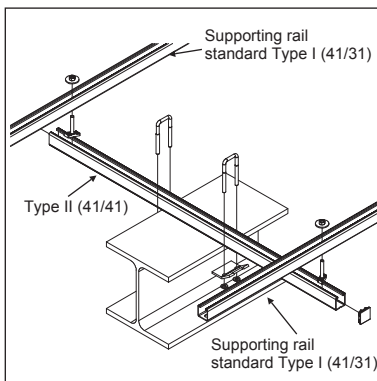

Pos. 4.2.11: Siaqua steel beam joint, elevated, double-sided

Application

To fasten a Siaqua supporting rail on or under steel beams. Observe permissible fastening distances!

Scope of delivery

2x M10 clamps; 2x cover caps type II 2x hook screws (HZ) 41 M10x55
Shorten the installation rail type II to the existing material.

Installation

Fasten the installation rail using clamps on the steel beam (tightening torque: 30 [Nm]).
Position the supporting rail onto the installation rail. Fasten the installation rails using the hook screw.

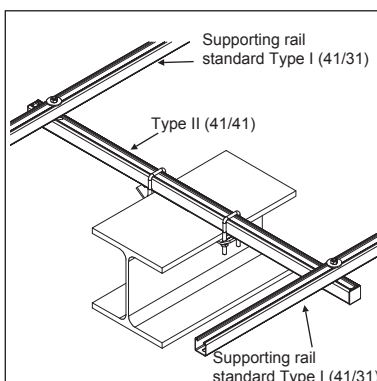

Article number

Position number	Art.No.
4.2.11	602137

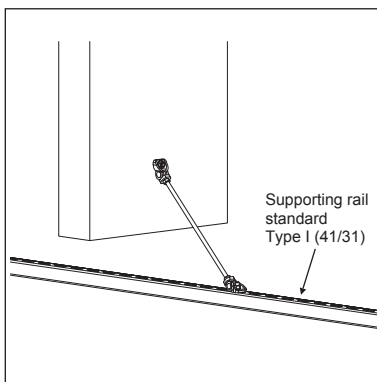
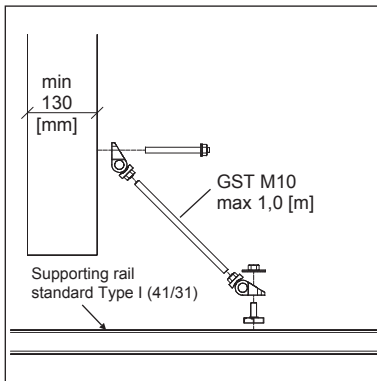
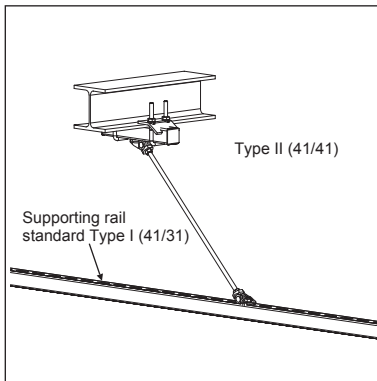
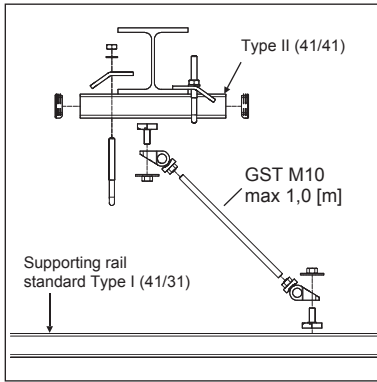

Pos. 4.3.1: Siaqua fixed structural point, steel

Application

Fixed structural points are used to prevent the system from swinging.
Arrangement of the fixed structural points in the direction of flow on tensile load:
-At the start and at the end of every pipe with supporting rail
-Every 10-12 metres

Scope of delivery

2x M10 clamps; 2x cover caps, Type II
2x M10 universal joints; 2x M10x20 hook screws; M10 threaded rod Shorten installation rail type II to the existing material.

Installation

Fasten the installation rail using clamps under the steel beam (tightening torque: 30 [Nm]). Mount a universal joint to the installation rail using a hook screw. Tighten the threaded rod (max. 1.0 [m]) to the universal fitting. Screw the second universal fitting onto the end of the threaded rod. Fasten the universal fitting onto the back of the supporting rail using a hook screw so that a 45° angle is created.

Article number

Position number	Art.Nr.
4.3.1	604030

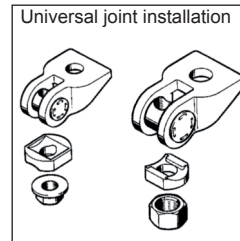

Pos 4.3.2: Siaqua fixed structural point, concrete

Application

Fixed structural points are used to prevent the system from swinging.
Arrangement of the fixed structural points in the direction of flow on tensile load:
-At the start and at the end of every pipe with supporting rail
-Every 10-12 metres

Scope of delivery

M10/30 wedge anchor; 2x M10 universal fittings; M10x20 hook screw; M10 threaded rod

Installation

Anchor the universal fitting into the concrete.
Tighten the threaded rod (max. 1.0 [m]) to the universal fitting. Screw the second universal fitting onto the end of the threaded rod. Fasten the universal fitting onto the back of the supporting rail using a hook screw so that a 45° angle is created.

Article number

Position number	Art.Nr.
4.3.2	604000

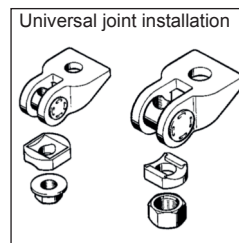

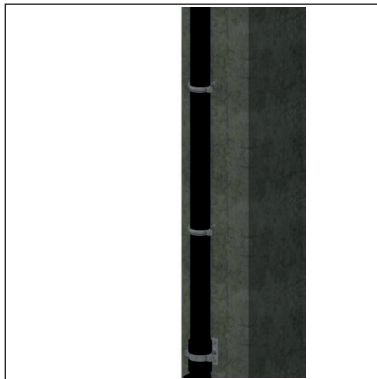

Pos 4.4 Siaqua down pipe joint

Application

To fasten down pipes

Arrangement

The fastening distance should be selected according to the table below:

Type	DN	40	50	56	63	75	90	100	125	150	200	250	300
Pipe clip distance [m]		1,0	1,0	1,0	1,0	1,0	1,3	1,6	1,8	2,4	3,0	3,7	4,7

Table 8: Permissible fastening distance for the Siaqua down pipe joint

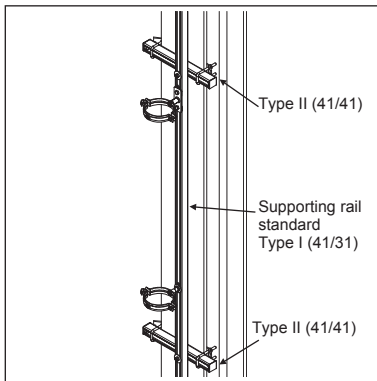

Note

- ▶ It is recommended to install a supporting rail as an alternative way to fasten the down pipe to steel support
 - ◆ The supporting rail must be standing on the ground
 - ◆ Fastening distance of rail: 2,5 m
 - ◆ Fasten to the steel beam using: „Elevated Siaqua steel beam joint“ (Pos 4.2.10)

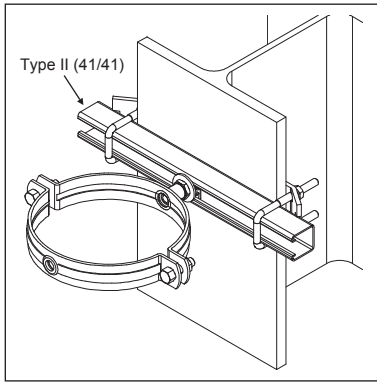

Pos. 4.4.1: Siaqua down pipe joint, steel, type I

Scope of delivery

2x M10 clamps; 2x cover caps, type II Siaqua standard fixture
 Shorten the installation rail type II to the existing material.

Installation

Fasten the installation rail using clamps on the steel beam flange (tightening torque: 30 [Nm]). Install the standard fixture

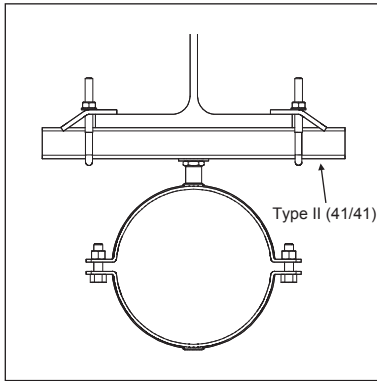

Article numbers

Positionnumber	Type	Art.No.
4.4.1.1	DN 40	603201
4.4.1.2	DN 50	603211
4.4.1.3	DN 56	603221
4.4.1.4	DN 63	603231
4.4.1.5	DN 70	603241
4.4.1.6	DN 90	603251
4.4.1.7	DN 100	603261
4.4.1.8	DN 125	603271
4.4.1.9	DN 150	603281
4.4.1.10	DN 200	603291
4.4.1.11	DN 250	603301
4.4.1.12	DN 300	603311

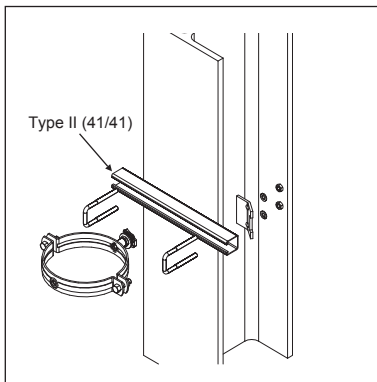

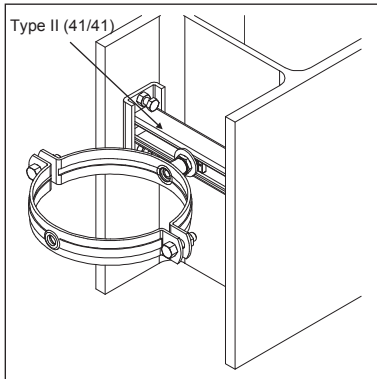

Pos. 4.4.2: Siaqua down pipe joint, steel, type II

Scope of delivery

2x clamp brackets Siaqua standard fastening
Shorten the installation rail type II to the existing material.

Installation

Fasten the installation rail between the steel beam flanges using the clamping brackets.
Install the standard fixture

Article numbers

Positionsnummer	Typ	Art.Nr.
4.4.2.1	DN 40	603601
4.4.2.2	DN 50	603611
4.4.2.3	DN 56	603621
4.4.2.4	DN 63	603631
4.4.2.5	DN 70	603641
4.4.2.6	DN 90	603651
4.4.2.7	DN 100	603661
4.4.2.8	DN 125	603671
4.4.2.9	DN 150	603681
4.4.2.10	DN 200	603691
4.4.2.11	DN 250	603701
4.4.2.12	DN 300	603711

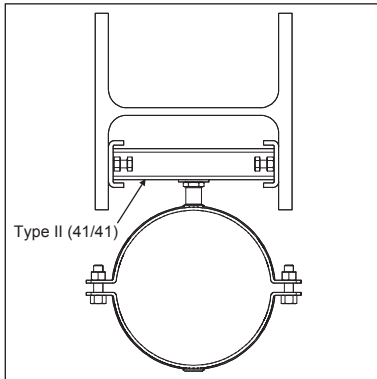

Pos. 4.4.3: Siaqua down pipe joint, concrete

Scope of delivery

DN40 - DN125:

M10x40 concrete anchor; M10/30 U washer; M10x53 threaded pin; M10 hexagonal nut; pipe clip

DN150 - DN300:

M10/10 wedge anchor; 1/2"/M10 adapter; pipe clip

Installation

DN40 - DN125:

Install the concrete anchor, tighten the threaded pin and secure with hexagonal nut.
Install the pipe clip.

DN150 - DN300:

Install the wedge anchor. The adapter is screwed onto the anchor. Install the pipe clip.

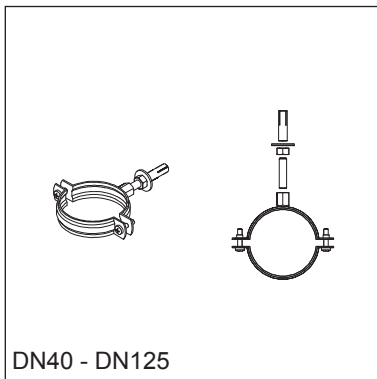

Article numbers

Positionsnummer	Typ	Art.Nr. (o.E.)	Art.Nr. (m.E.)
4.4.3.1	DN 40	602600	602605
4.4.3.2	DN 50	602610	602615
4.4.3.3	DN 56	602620	602625
4.4.3.4	DN 63	602630	602635
4.4.3.5	DN 70	602640	602645
4.4.3.6	DN 90	602650	602655
4.4.3.7	DN 100	602660	602665
4.4.3.8	DN 125	602670	602675
4.4.3.9	DN 150	602680	602685
4.4.3.10	DN 200	602690	602695
4.4.3.11	DN 250	602700	602705
4.4.3.12	DN 300	602710	602715

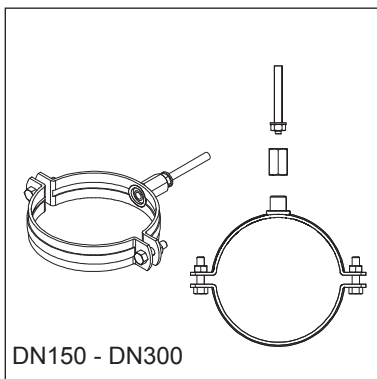



Pos 4.5 Siaqua down pipe fixed points

Application

To support the loads from the down pipe.

Arrangement

- At the start and the end of the hydraulic part of the down pipe
- In the event of any warping in the down pipe, additional fixed points must be attached immediately before and after the warping.
- If the flow calming section is longer than 2 m, the lowest fixed point should be positioned in the deceleration section.

Note

The fixed points should always be inserted together with electro-fusion sockets. See also examples on page 81 ff.

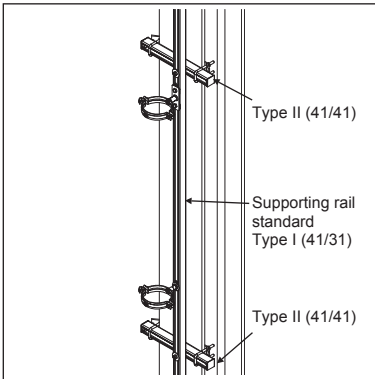

Note

- ▶ It is recommended to install a supporting rail as an alternative way to fasten the down pipe to steel support
 - ◆ The supporting rail must be standing on the ground
 - ◆ Fastening distance of rail: 2,5 m
 - ◆ Fasten to the steel beam using: „Elevated Siaqua steel beam joint“ (Pos 4.2.10)

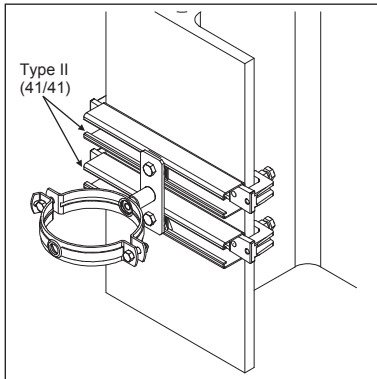

Pos. 4.5.1: Siaqua down pipe fixed point, steel, type I

Scope of delivery

4x fixing clamps TCS I Siaqua fixed point
Shorten the installation rail type II to the existing material.

Installation

Fasten the installation rails using the fixing clamps on the steel beam flange. Fasten the Siaqua fixed point using the installation rails.

Note

From sizes above DN200, two fixed points must be installed (see example 3 on page 67).

Article numbers

Position number	Type	Art.No.
4.5.1.1	DN 40	603401
4.5.1.2	DN 50	603411
4.5.1.3	DN 56	603421
4.5.1.4	DN 63	603431
4.5.1.5	DN 70	603441
4.5.1.6	DN 90	603451
4.5.1.7	DN 100	603461
4.5.1.8	DN 125	603471
4.5.1.9	DN 150	603481
4.5.1.10	DN 200	603491
4.5.1.11	DN 250	603501
4.5.1.12	DN 300	603511

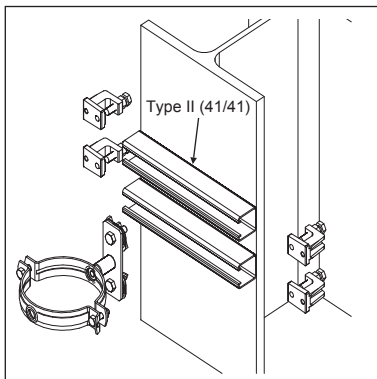
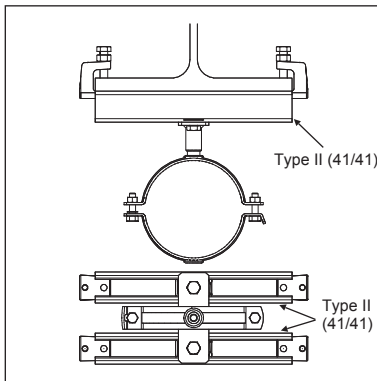

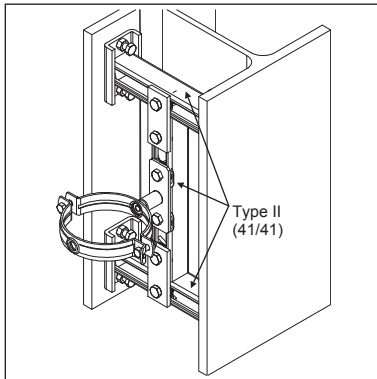

Pos 4.5.2 Siaqua down pipe fixed point, steel type II

Scope of delivery

4x clamping brackets, 2x corner plates ECO CC1
Siaqua fixed point; from DN200 onwards, 2x Siaqua fixed points Shorten installation rail type II to existing material.

Installation

Fasten the installation rails between the steel beam flanges using the clamping brackets. Fasten the vertical rail with the corner plates. Install the Siaqua fixed point.

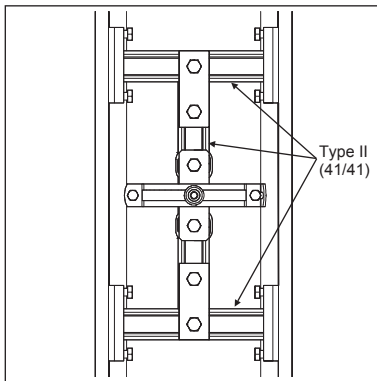

Article numbers

Position number	Type	Art.No.
4.5.2.1	DN 40	603801
4.5.2.2	DN 50	603811
4.5.2.3	DN 56	603821
4.5.2.4	DN 63	603831
4.5.2.5	DN 70	603841
4.5.2.6	DN 90	603851
4.5.2.7	DN 100	603861
4.5.2.8	DN 125	603871
4.5.2.9	DN 150	603881
4.5.2.10	DN 200	603891
4.5.2.11	DN 250	603901
4.5.2.12	DN 300	603911

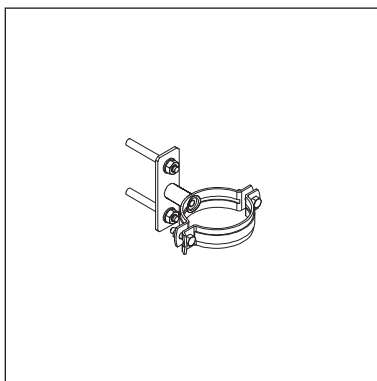

Pos. 4.5.3: Siaqua down pipe fixed point, concrete

Scope of delivery

2x M10/10 wedge anchors; Siaqua fixed point

Installation

Remove the CC connection parts. Install the fixed point with two wedge anchors.

Note

From dimensions over DN200, two fixed points must be installed (see example 3 on page 67).

Article numbers

Position number	Type	Art.No. (w/o.ln.)	Art.No. (w.ln.)
4.5.3.1	DN 40	602500	602505
4.5.3.2	DN 50	602510	602515
4.5.3.3	DN 56	602520	602525
4.5.3.4	DN 63	602530	602535
4.5.3.5	DN 70	602540	602545
4.5.3.6	DN 90	602550	602555
4.5.3.7	DN 100	602560	602565
4.5.3.8	DN 125	602570	602575
4.5.3.9	DN 150	602580	602585
4.5.3.10	DN 200	600946	600947
4.5.3.11	DN 250	600948	600949
4.5.3.12	DN 300	600950	600951

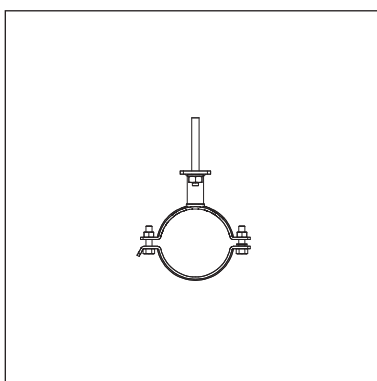

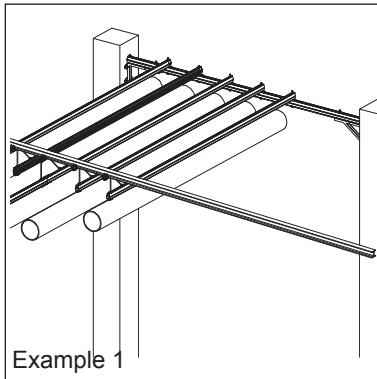

Pos. 4.6: Siaqua customised constructions

Application

Customised constructions are designed depending on the particular structural conditions.

Note

The examples below are of different customised constructions.

Example 1

Cross beams stretched over axle structure

Example 2

Cross beam stretched over axle structure at different suspended heights

Example 3

Special fixed point

Example 4

Down pipe bracket

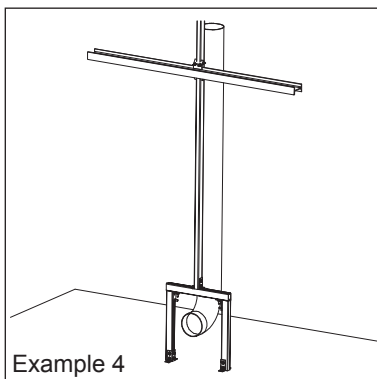
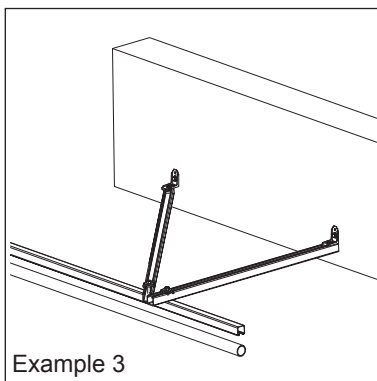
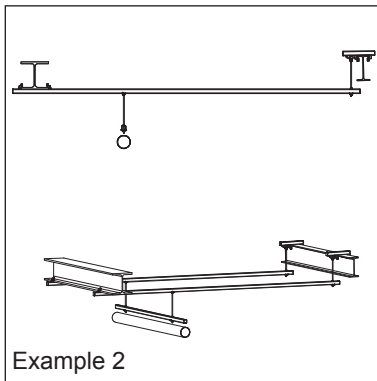

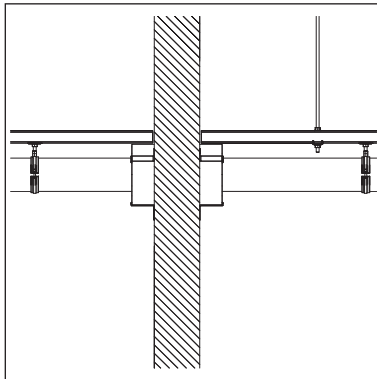
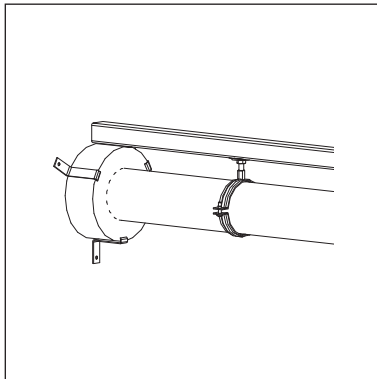

Pos. 5.1: Siaqua fire protection sleeve

Application

Sleeve for the fire-resistant sealing of combustible pipes in accordance with DIN 4102-11

Technical data

Fire resistance class: R90

Article numbers

Positionsnummer	Typ	Art.Nr.
5.2.2	DN 50	600909
5.2.3	DN 56	600910
5.2.4	DN 63	600910
5.2.5	DN 70	600911
5.2.6	DN 90	600912
5.2.7	DN 100	600913
5.2.8	DN 125	600914
5.2.9	DN 150	600915
5.2.10	DN 200	600916
5.2.11	DN 250	600917
5.2.12	DN 300	600918

Fire protection roof drain see pos 1.5 page 32.

IV Examples

Installation examples

Roof drain connection	page 81
Arrangement of welded sockets with a combined socket/gravity welding	page 82
Fixed rail point	page 83
Down pipe offset	page 84

Pipework diagram- installation

Tee with reducer	page 84
Stub lines / bends	page 85
Down pipe	page 86

Roof drain connection

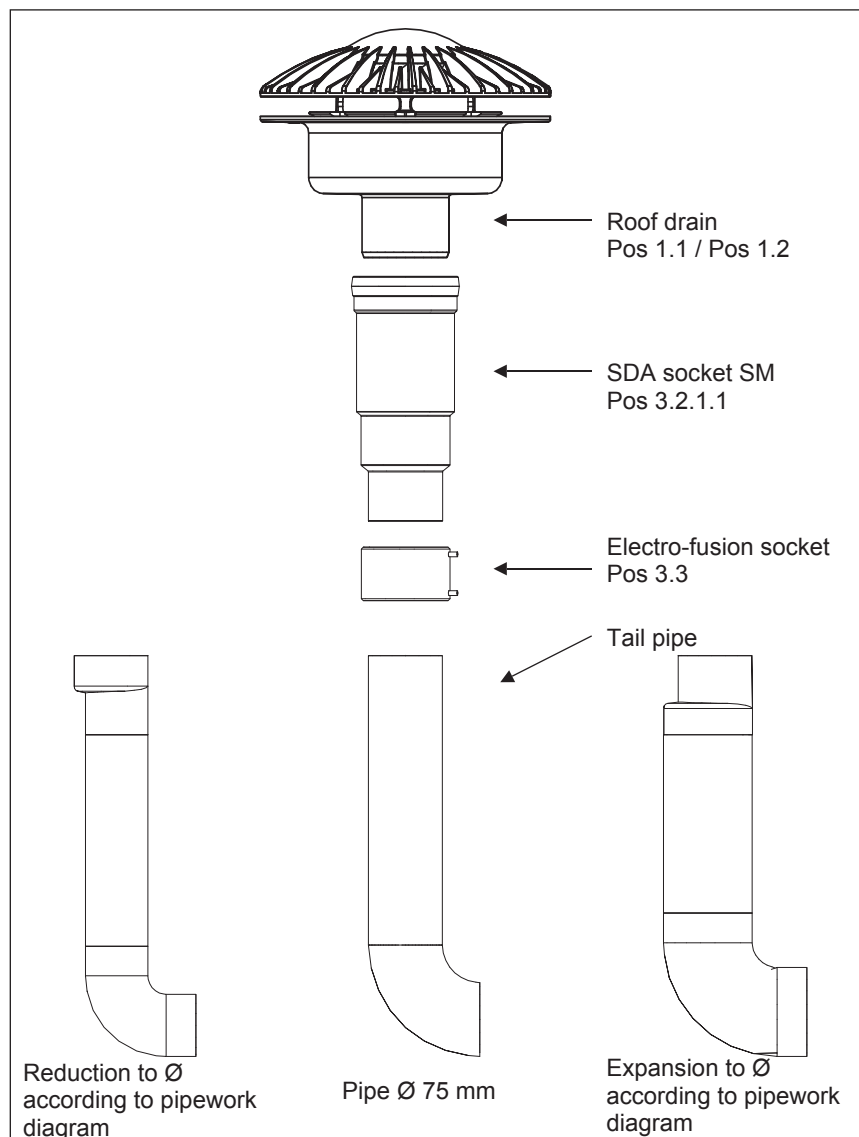

Note

- ▶ A SDA socket SM with integrated snap ring (Pos 3.2.1.1) is used to connect the PE-HD pipe to the roof drain.

Installation procedure:

1. A roofer must install the drain
2. Insert the snap ring socket until it „clicks“
3. Prepare the tail pipe with butt-welding on the ground. Adjust the tail pipe on the roof drain.
4. Weld the PE-HD pipe using an electro-fusion socket (Pos 3.3)

Caution

- ▶ The bend under the drain should always be designed with a 88,5° elbow.

Arrangement of welded sockets with combined socket/butt-welding

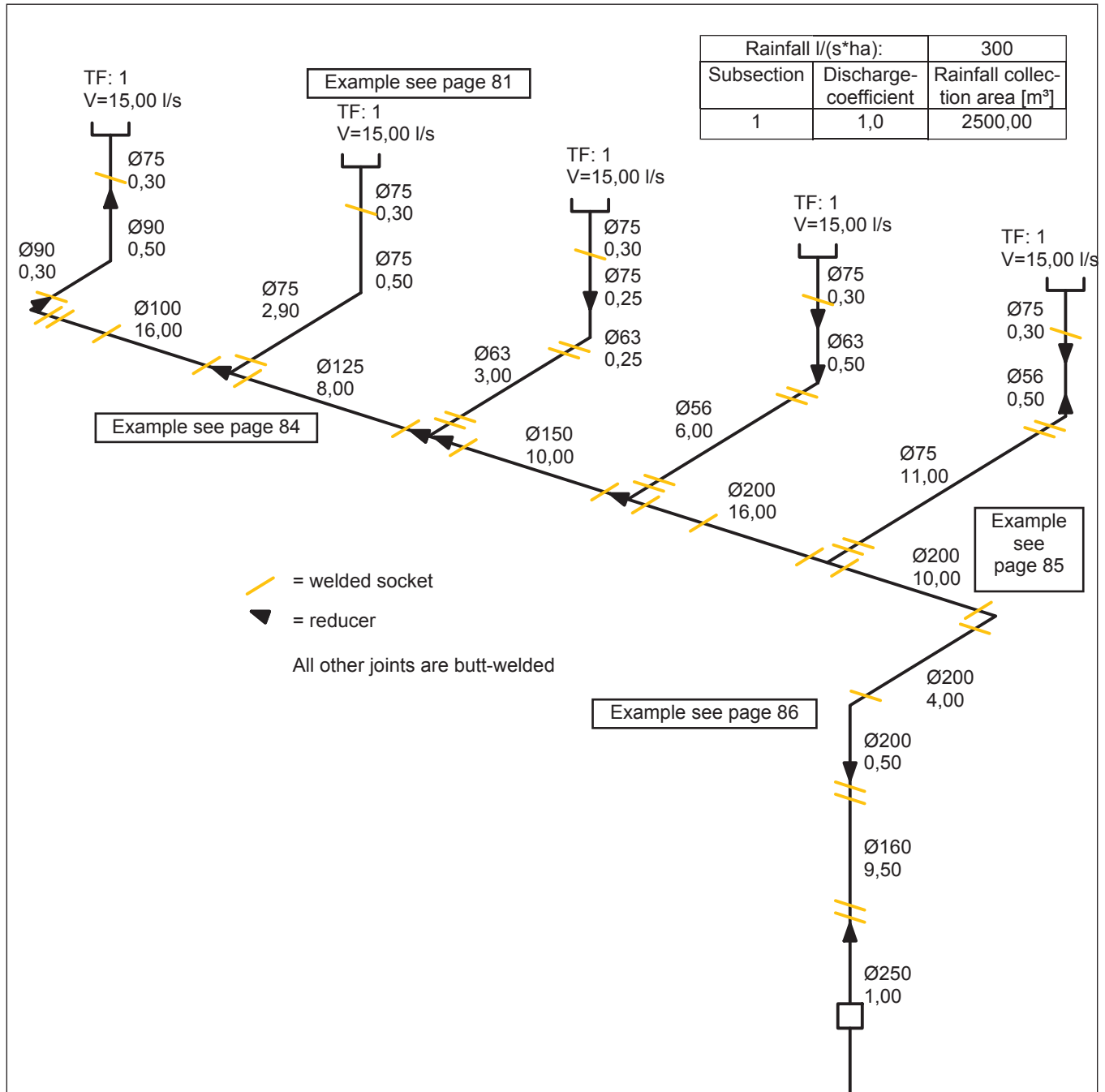

The following socket connections **are required**:

- ◆ Always when a fixed point must be installed
- ◆ Connection of single connection pipes on the drainage and on the tee
- ◆ Installation of a tee in the pipework
- ◆ In smooth pipelines, at the latest after 10m

The following welded socket joints **are not required** and can be replaced with butt-welding:

- ◆ Complete single connection pipes incl. fittings
- ◆ Reducer directly on a tee
- ◆ Total flow calming section (\leq DN250)
- ◆ Smooth pipe length up to 10 m

Fixed rail point

DN 40 - DN 150

Installation procedure:

1. Push the ends into a socket (fixed point socket).
2. Slide the fixed point socket onto the pipe and insert the pipe into the fixed point clip.
3. Weld pipes using joint socket and leave to cool.
4. Slide and positively lock fixed point clips onto the joint socket and securely fasten.
5. Slide the fixed point socket against the pipe clip and weld together.

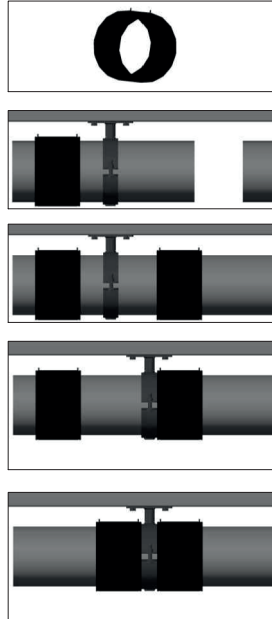

DN 200 - DN 300

Installation procedure:

1. Press fixed point clips into the installation rail and loosely insert the pipes.
2. Weld pipes using electro-fusion sockets and leave to cool.
3. Slide and positively lock fixed point clips onto the joint socket and securely fasten.

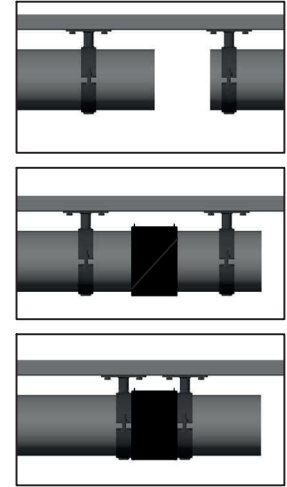

Possible installation situation: Fixed points on the offset to downpipe

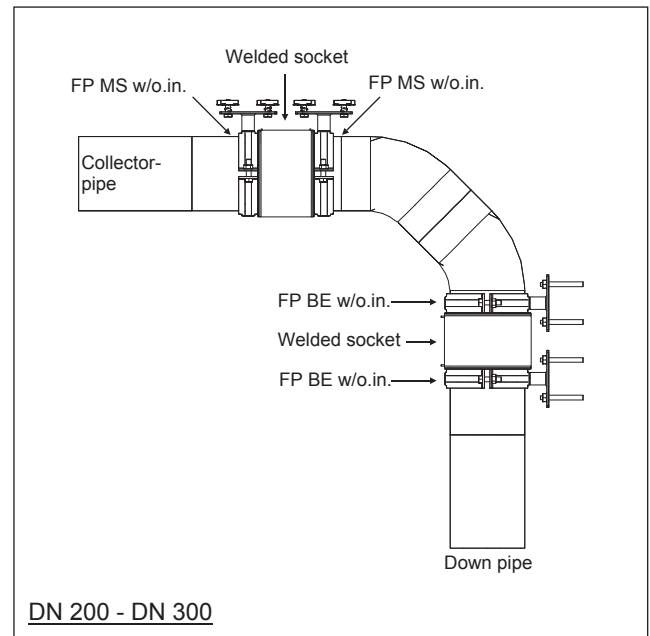
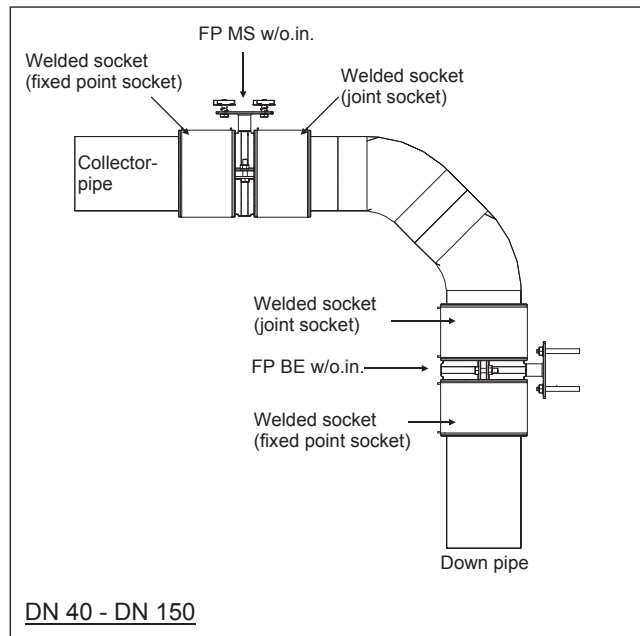

Down pipe offset

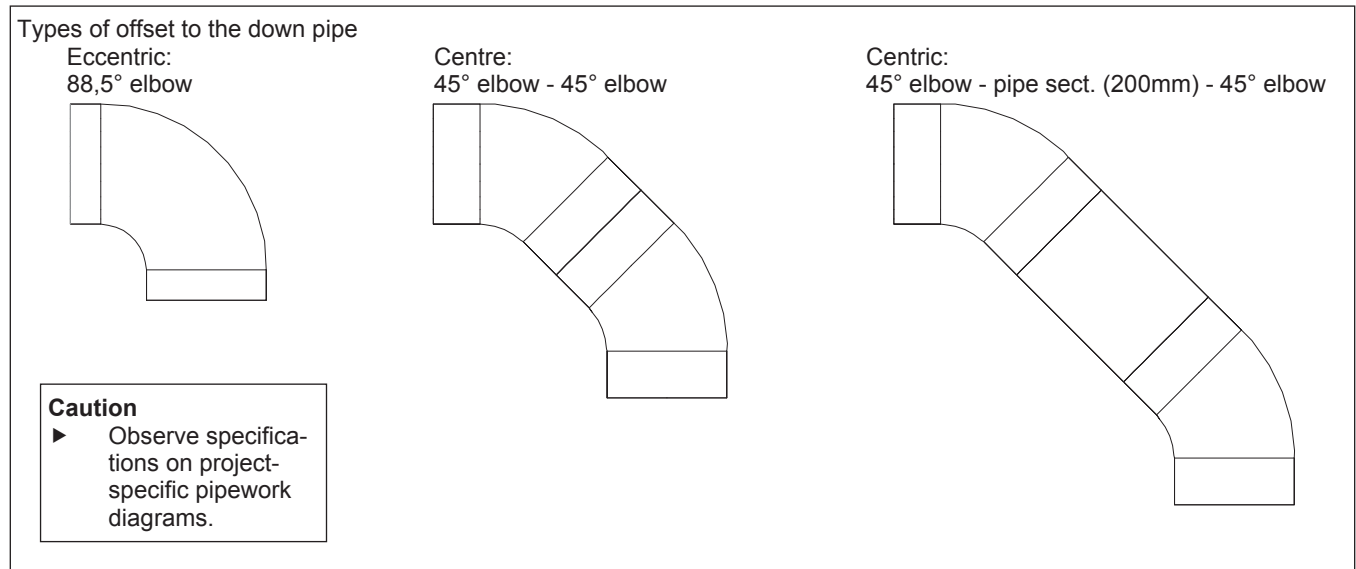

Tee with reducer

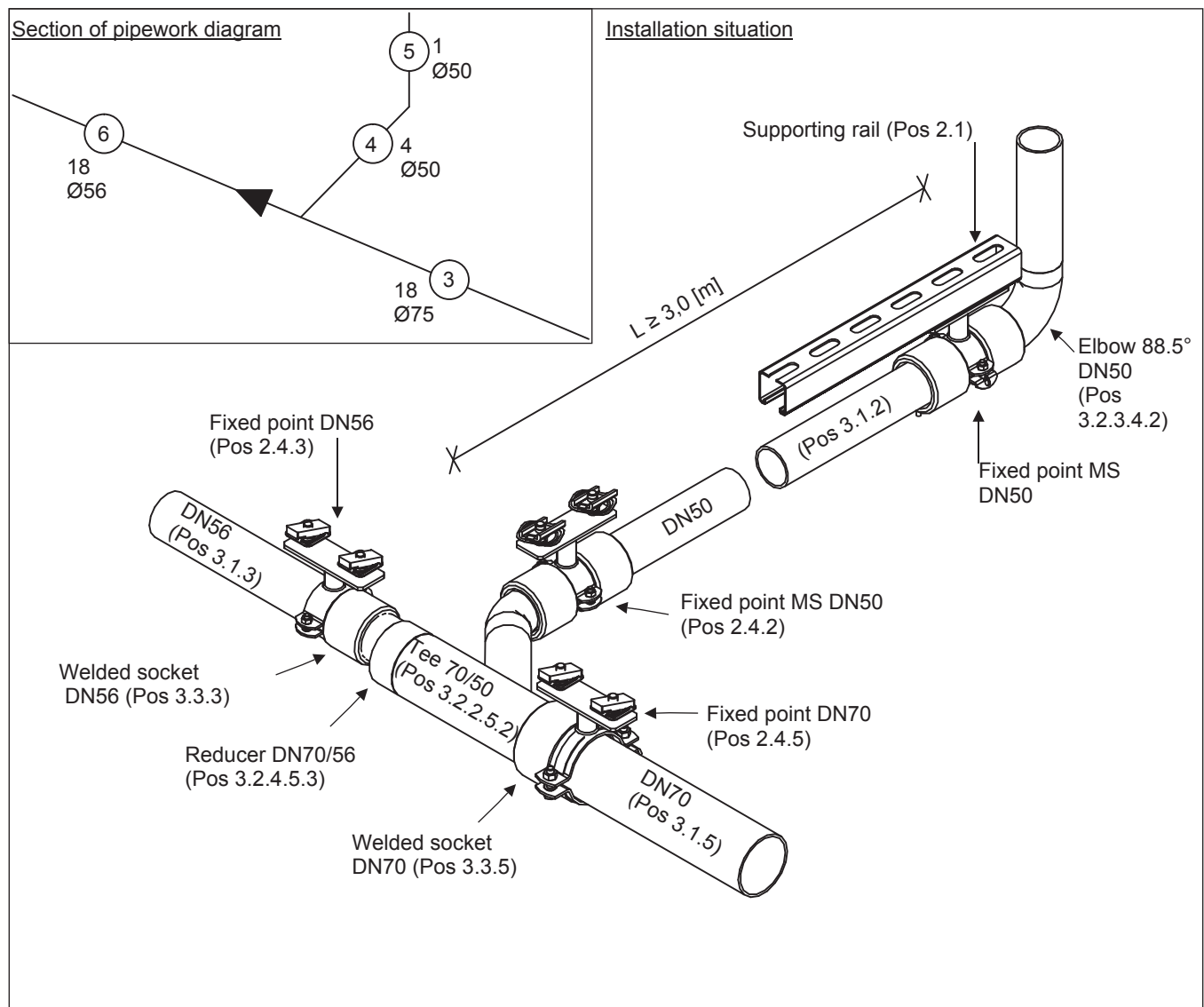

Stub lines / bends

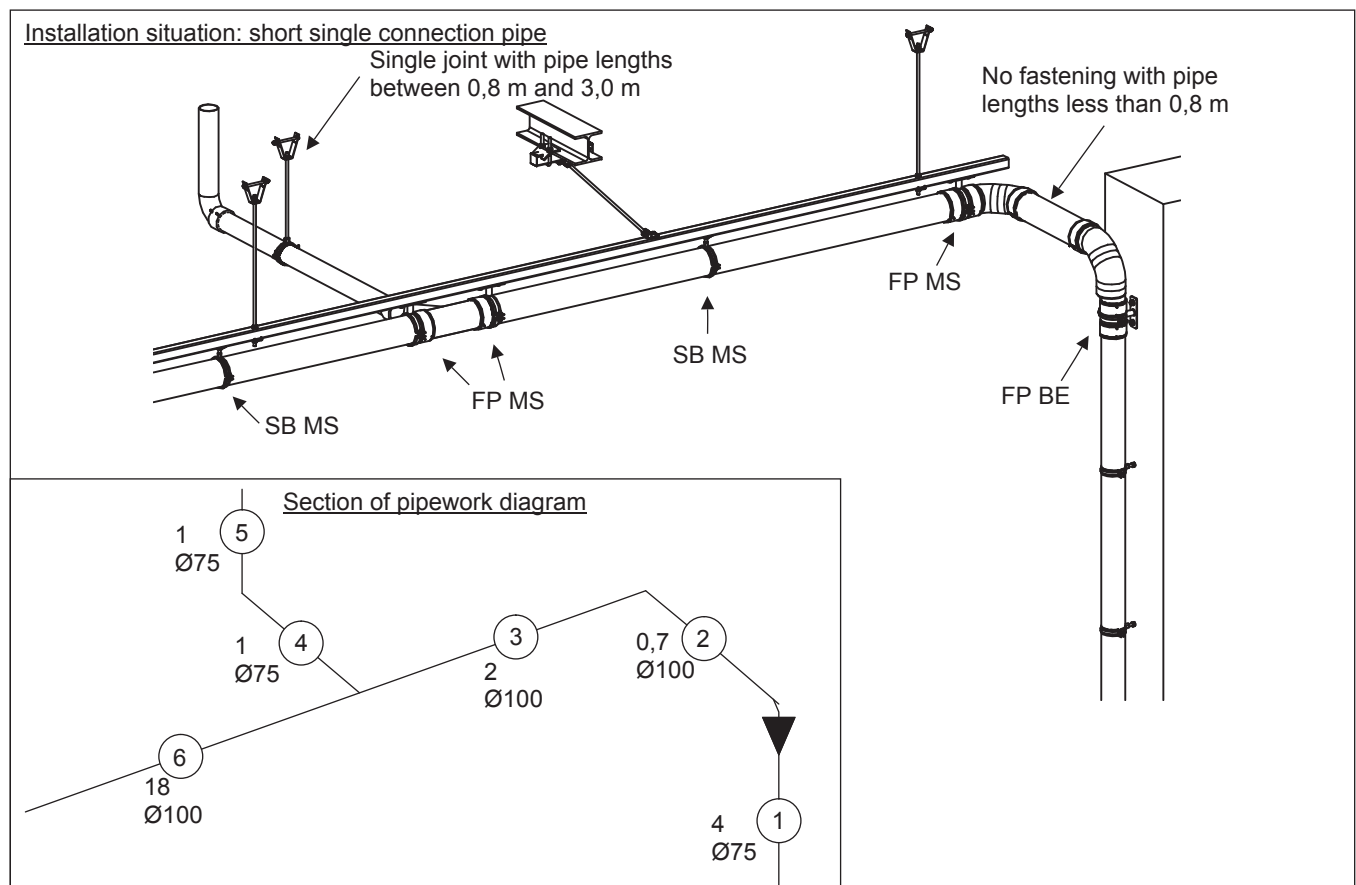
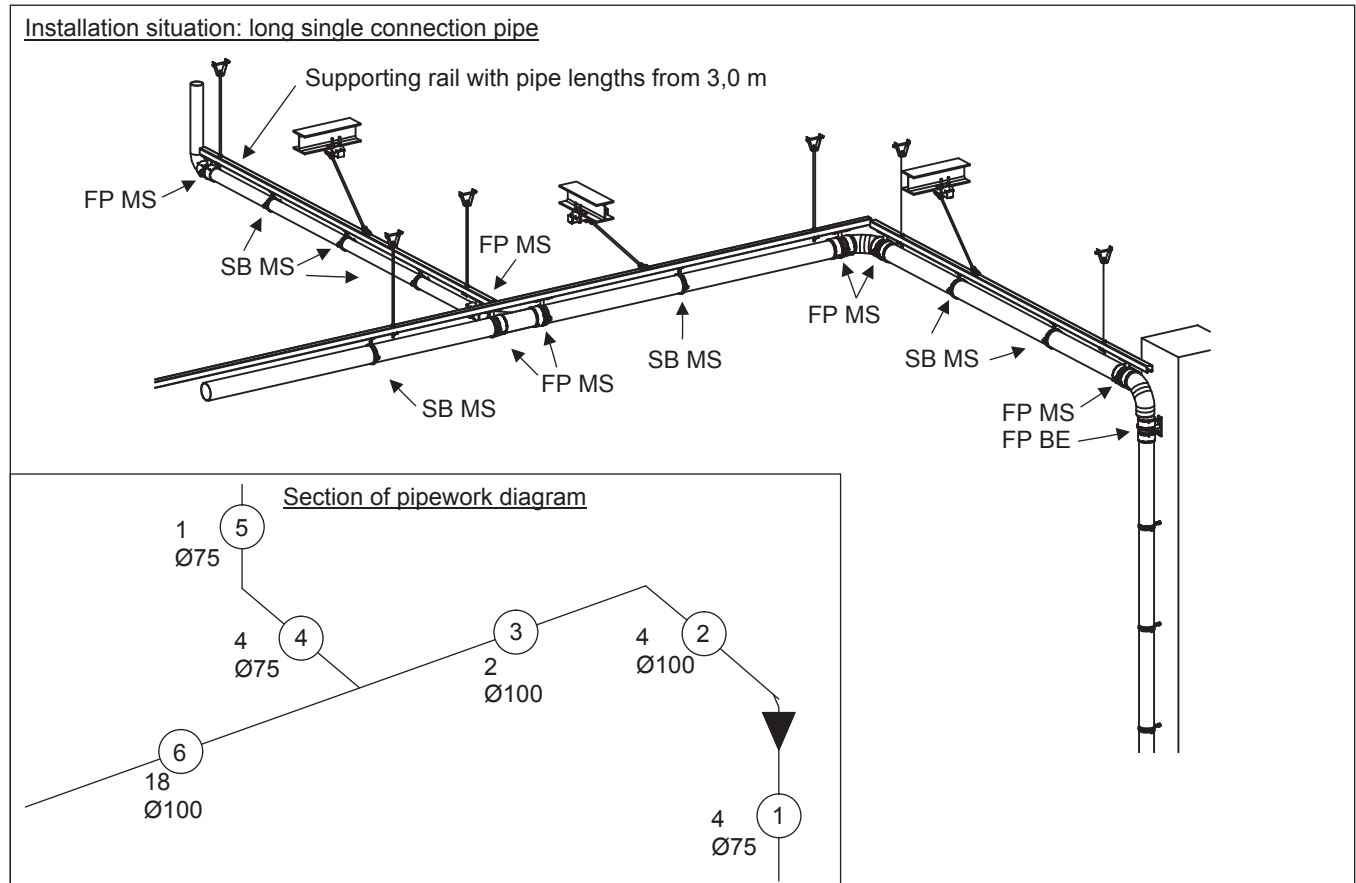

Down pipe

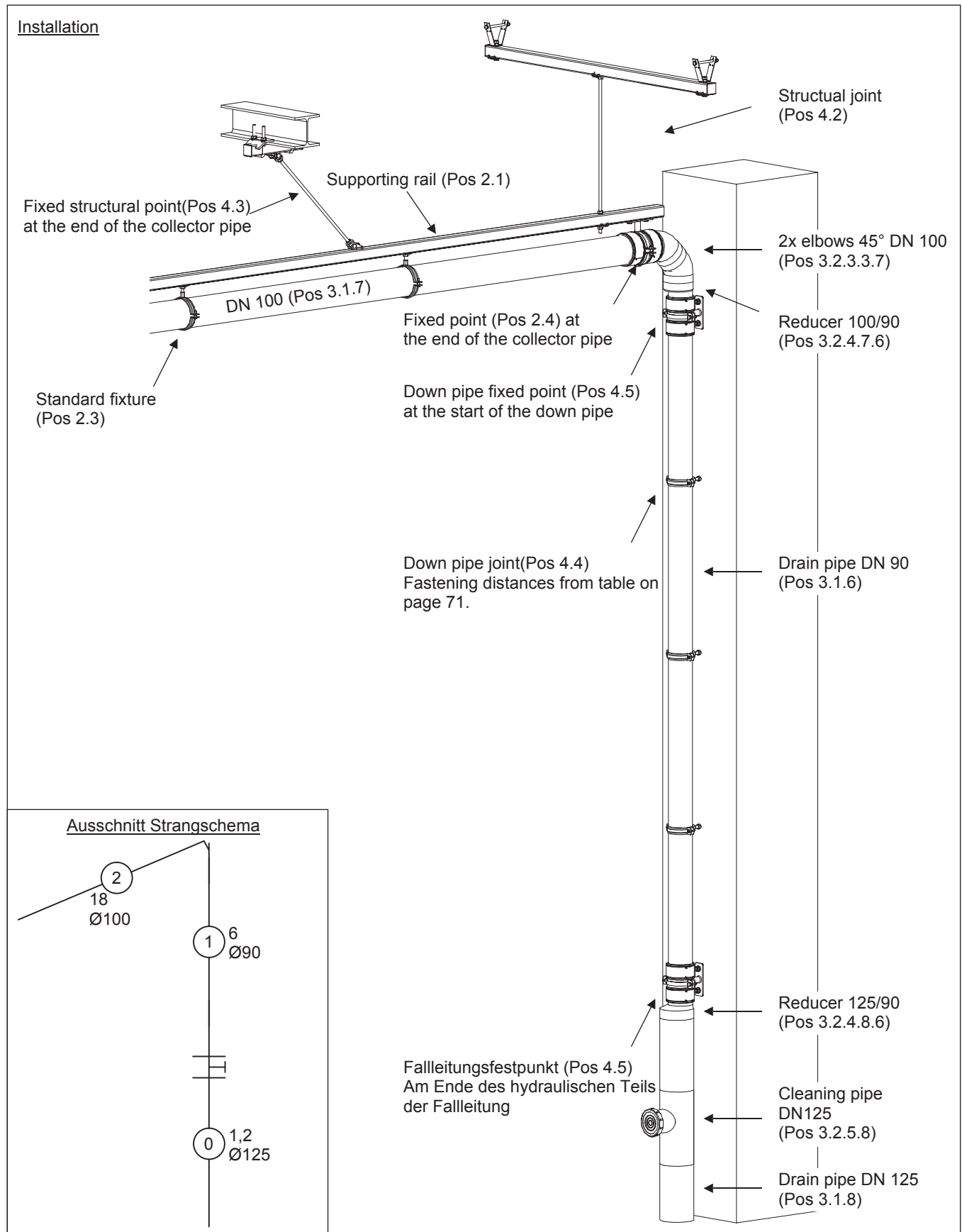

Notes

- ◆ It must be checked with the customer if the initiated loads can be supported by the building structure
- ◆ Anchors must be installed in accordance with the manufacturer's instructions. The clearance distances and the minimum part thickness must be observed in particular
- ◆ Also observe zones where it is not permitted to drill
- ◆ The specific installation instructions for each part must be observed for installation
- ◆ The actual design of the Siaqua roof drainage may vary from the illustrations in individual cases.

Verkaufs, Lieferungs- und Zahlungsbedingungen

1. Diese Allgemeinen Geschäftsbedingungen (AGB) sind Bestandteil aller unserer Verträge über Warenlieferungen, Reparaturleistungen, und sonstigen Leistungen; bei laufenden Geschäftsbeziehungen mit Kaufleuten gelten sie in ihrer jeweiligen, in unseren Waren- und/oder Preislisten abgedruckten Fassung auch für künftige Verträge; auch mündlich, fernmündlich, per Fax oder EDV erteilte Aufträge nehmen wir nur unter Einbeziehung unserer jeweils geltenden AGB an. Entgegenstehende oder von unseren Verkaufsbedingungen abweichende Bedingungen des Kunden erkennen wir nur an, wenn wir ausdrücklich schriftlich der Geltung zugestimmt haben.

Unsere AGB gelten als vom Käufer angenommen, wenn ihnen nicht sofort bei Auftragserteilung widersprochen wird. Einkaufsbedingungen unserer Kunden bzw. Verkaufsbedingungen unserer Lieferanten sind, soweit sie mit diesen AGB im Widerspruch stehen, für uns unverbindlich, auch wenn wir ihnen nicht ausdrücklich widersprochen haben. Uns erteilte Aufträge sind erst dann durch uns angenommen, wenn sie durch uns schriftlich bestätigt worden sind oder wenn die Lieferung durch uns stillschweigend erfolgt ist.

2. Werden uns Aufträge per Internet oder E-Mail erteilt, so kommt ein Vertrag nur zustande, wenn wir den Auftrag schriftlich bestätigt haben.

3. Unsere Außendienstmitarbeiter sind grundsätzlich nur zur Vermittlung von Aufträgen befugt; ein Auftrag gilt erst als genommen, wenn er von unserer Hauptverwaltung oder einer unserer Verkaufsstellen schriftlich bestätigt ist oder wenn die Ware ausgeliefert ist. Individuelle Vertragsabreden, insbesondere bestimmte Eigenschaftszusicherung oder Verwendungsempfehlungen für unsere Waren, Angaben über Lieferfristen, Rabatte und Boni sowie etwaige Kulanzabsprachen bedürfen zur Rechtswirksamkeit der ausdrücklichen schriftlichen Bestätigung unserer Hauptverwaltung, es sei denn, dass für mündliche Erklärungen nach Handelsrecht oder Rechtscheingrundsätzen Vertragsabschlussvollmacht besteht.

Telefonische oder mündliche Ergänzungen bzw. Änderungen bedürfen zu ihrer Wirksamkeit ebenfalls einer schriftlichen Bestätigung. Unsere Angebote sind nicht bindend. An den in unseren Katalogen und Prospekten enthaltenen Abbildungen und Zeichnungen sowie an Mustern oder anderen Unterlagen behalten wir uns das Eigentums- und Urheberrecht vor. Diese Unterlagen dürfen ohne unsere Genehmigung Dritten nicht zugänglich gemacht werden und sind auf Anforderung sofort zurückzugeben. Der Nachdruck, ganz oder teilweise, ist nicht gestattet. Die Maß- und Gewichtsangaben sind unverbindlich. Eine Änderung der Konstruktion, Maße und Gewichte behalten wir uns vor. Die in unseren Katalogen und Prospekten genannten technischen Daten stellen unverbindliche Richtwerte dar.

4. Es gelten die in unserer jeweils gültigen Preisliste genannten Verkaufspreise oder die Abrechnung erfolgt auf Basis des entsprechenden Angebotes mit der dazugehörigen Stückliste zuzüglich der zurzeit gültigen Mehrwertsteuer ab Werk. Sollte nachträglich, bedingt durch bauliche Gegebenheiten, die zum Zeitpunkt der Planung nicht bekannt waren, zusätzliches Material benötigt oder Überplanungen durch das Projektengineering notwendig werden, wird dieses als Nachtrag gesondert berechnet. Die

am Tag der Auftragserteilung geltenden Preise werden berechnet, wenn die Lieferung innerhalb einer Frist von 4 Monaten ab Auftragserteilung erfolgt.

Bei späteren (Teil-) Lieferungen (z. B. bei Abrufaufträgen) behalten wir uns Preisberichtigungen vor.

Bei Zahlungsverzug und insbesondere bei gerichtlicher Beitreibung werden sämtliche noch offenen Rechnungen sofort zur Zahlung fällig; ferner entfallen etwa bewilligte Rabatte, Boni etc. Gleiche Rechtsfolgen treten ein, wenn über das Vermögen des Käufers ein gerichtliches Insolvenzverfahren eingeleitet wird. Mit einer Gegenforderung kann nur aufgerechnet werden, wenn sie von uns unbestritten oder wenn sie rechtskräftig festgestellt ist. Für Kleinaufträge im Nettowarenwert unter € 50,00 müssen wir uns die Berechnung eines Mindermengenzuschlages von € 12,50 vorbehalten.

Die Preise der von uns unterbreiteten Angebote sind freibleibend; sie gelten nur bei sofortiger Bestellung. Jede Warenlieferung wird am Tag der Lieferung an den Kunden fakturiert. Unsere Rechnungen sind zahlbar innerhalb von 30 Tagen nach Rechnungsdatum (nicht nach Rechnungs- oder Wareneingang). Bei Barzahlung innerhalb von 10 Tagen ab Rechnungsdatum gewähren wir 2 % Skonto vom Rechnungsendbetrag unter der Voraussetzung, dass alle fälligen Rechnungen beglichen sind. Die Zahlungsfrist ist gewahrt, wenn der Überweisungs- oder Scheckbetrag innerhalb der Frist einem unserer Konten gutgeschrieben ist.

Die Rüge angeblicher Mängel befreit den Käufer nicht von seinen Zahlungspflichten. Mehrkontoabzüge bzw. Skontoabzüge über Termin sowie Kürzung von Versand- und Verpackungskosten anerkennen wir nicht. Bei Überschreitung des Zahlungsziels sind wir berechtigt, ab Fälligkeit vertragliche Fälligkeitszinsen in Höhe banküblicher Sollzinsen, mindestens aber 8 % p. a. Über dem jeweiligen Basiszinssatz zu berechnen sowie weitere Lieferungen zurückzustellen oder abzulehnen.

5. Vorgerichtliche Kosten, insbesondere Mahnkosten, können wir - unbeschadet des Nachweises höherer oder geringerer Kosten - pauschal mit € 15,00 geltend machen, Schecks und Wechsel werden nur erfüllungshalber angenommen. Diskont- und sonstige Spesen gehen zu Lasten des Käufers. Kunden, die uns nicht bekannt sind, beliefern wir nur per Nachnahme unter Abzug von 3 % Skonto. Dem Kundenkonto in unserem Haus liegt ein Kreditrahmen zu Grunde, der sich an der Warenkreditversicherung durch Firma Euler Hermes bemisst. Sollte dieser Kreditrahmen innerhalb des vereinbarten Zahlungszieles komplett ausgeschöpft sein und wir über Firma Euler Hermes keinen höheren Versicherungsrahmen erhalten, behalten wir uns vor, die Zahlungsbedingungen zu ändern und darauf hinzuweisen, dass offene Forderungen vor der nächsten Lieferung beglichen werden müssen. Unbefriedigende Auskünfte über die Bonität des Kunden berechtigen uns, nachträglich andere Zahlungsbedingungen zu stellen und/oder Sicherheiten oder Vorauszahlungen zu verlangen. Unsere Außendienstmitarbeiter sind ohne ausdrückliche Inkassovollmacht nicht berechtigt, Zahlungen entgegenzunehmen.

6. Lieferfristen sind für uns nur verbindlich, wenn wir dies ausdrücklich schriftlich zugesichert haben. Sie beginnen mit

dem Datum der Auftragserteilung und gelten nur vorbehaltlich richtiger und rechtzeitiger Selbstbelieferung. Zugesicherte Lieferfristen gelten als eingehalten, wenn die Versandbereitschaft der Ware gemeldet ist. Die zugesicherten Lieferfristen werden durch Ereignisse höherer Gewalt und durch Betriebs- oder Verkehrsstörungen in angemessenem Umfang verlängert. Solche Ereignisse berechtigen uns außerdem, vom Vertrag insoweit zurückzutreten, als die Ware noch nicht geliefert und innerhalb einer angemessenen verlängerten Lieferfrist mangels Selbstbelieferung nicht beschafft werden kann. Wir sind nicht zum Ersatz von Schäden verpflichtet, die in Folge verzögerter Liefertermine hervorgerufen durch Betriebs- oder Verkehrsstörungen, unvorhergesehene Schwierigkeiten bei der Rohstoff- und Betriebsmittelbeschaffung bzw. bei der Selbstbelieferung oder durch Fälle höherer Gewalt, eingetreten sind. Teillieferungen sind auf Kosten des Käufers möglich. Bei Nichtangabe einer Versandvorschrift wird der uns am günstigsten erscheinende Transportweg gewählt, ohne eine Verantwortlichkeit für billigste Verfrachtung und ordnungsgemäße Ankunft der Ware. Unsere normalen Regellieferzeiten lauten wie folgt und sind für uns unverbindlich:

48 Stunden für Stückgut
72 Stunden für Langgut
ab Warenversand
Zustellung im Laufe des Tages

Die Regellaufzeit bezieht sich ausschließlich auf Werktage ohne Wochenenden und Feiertage.

Termin- und Expresslieferungen können kostenpflichtig durch den Kunden an uns beauftragt werden. Übergabeort der Ware an den Kunden ist unser Lager in Hagen. Der Versand erfolgt auf Gefahr des Käufers, unabhängig davon, ob die Versendung der Ware vom Erfüllungsort erfolgt oder wer die Frachtkosten trägt. Wir liefern ab einem Nettowarenwert von 125,00 € innerhalb Deutschlands frei Haus oder frei Baustelle an die von Kunden schriftlich benannte Adresse. Die Warenanlieferung erfolgt „frei Ladekante Lkw“. Die Gefahr für den Zustand der Lieferung geht mit der Zustellung der Ware auf den Kunden über. Wir liefern frei Ladekante.

7. Unsere Lieferungen erfolgen unter erweitertem Eigentumsvorbehalt. Die Ware darf ohne Offenlegung der Eigentumsverhältnisse an Dritte weder verpfändet noch übereignet werden insoweit tritt der Kunde die ihm darauf entstehenden Forderungen gegen seine Kunden mit allen Nebenrechten schon jetzt an uns in Höhe des Wertes dieser Vorbehaltsware ab. Wir nehmen diese Abtretung hiermit an. Das uns vorbehaltene Eigentum sowie die gemäß Vorstehendem abgetretenen Forderungen dienen der Sicherung sämtlicher, auch künftiger, Forderungen aus der Geschäftsbeziehung mit dem Kunden, soweit und solange Forderungen zu unseren Gunsten bestehen.

Wir verpflichten uns, die uns nach den vorstehenden Bedingungen zustehenden Sicherheiten auf Verlangen des Kunden insoweit freizugeben, als ihr realisierbarer Wert die zu sichernden Forderungen um 20% übersteigt. Nehmen wir auf Kaufpreiszahlungen erfüllungshalber Schecks und/oder Wechsel an, so erlischt der Eigentumsvorbehalt erst mit deren ordnungsgemäßer Einlösung. An den uns etwa zur Reparatur abgegebenen Gegenständen entsteht, auch wenn der Reparaturgegenstand nicht im Eigentum des

Auftraggebers steht, für uns ein Vertragspfandrecht für alle unsere Forderungen aus dem Reparaturauftrag.

8. Unsere Lieferungen und Rechnungen hat der Kunde unverzüglich zu prüfen und etwaige Mängel oder Fehler im Sinne der §§ 377, 378 HGB unverzüglich zu rügen. Andernfalls gilt die Lieferung bzw. Rechnung als vertragsgemäß anerkannt. Für etwaige Mängel an den uns gelieferten Produkten und unseren Reparaturen leisten wir, soweit nicht darüber hinaus gesondert Garantie erteilt wurde, Gewähr innerhalb der gesetzlichen Fristen nach geltendem Kaufrecht nach unserer Wahl durch Nachbesserung oder bei Warenlieferung auch durch Ersatzlieferung oder Gutschrift der Ware. Schlagen diese fehl, so kann der Kunde nach seiner Wahl Herabsetzung der Vergütung oder bei Warenlieferung auch Rückgängigmachung des Kaufvertrages (Wandlung) verlangen. Zum Nachweis des Mangels und der Einhaltung der Gewährleistungspflicht ist Vorlage des defekten Produktes einschließlich zugehöriger Rechnung erforderlich. Im Übrigen sind Warenrücknahme, Umtausch oder sonstige Reklamationen ausgeschlossen.

Unsere Haftung für zugesicherte Eigenschaften ist auf den Ersatz des unmittelbaren Schadens beschränkt, es sei denn, die Zusicherung hätte ausdrücklich das Ziel verfolgt, den Kunden gerade gegen den eingetretenen Mangel- folgeschaden abzusichern. Kenntnis und Beachtung der für die Verwendung unserer Produkte einschlägigen DIN-Normen und Verwendungsvorschriften ist in jedem Falle Sache unseres Kunden.

Im übrigen ist unsere Haftung sowie die Haftung unserer gesetzlichen Vertreter und Erfüllungsgehilfen ausgeschlossen, es sei denn, sie beruhe auf Vorsatz oder grober Fahrlässigkeit unserer gesetzlichen Vertreter und Erfüllungsgehilfen oder sie beruhe auf einer schuldhaften Verletzung einer Kardinalspflicht oder einer sonstigen wesentlichen Vertragspflicht aus Unmöglichkeit, Verzug, positiver Forderungsverletzung, Verschulden bei Vertragsabschluss, Verletzung von Nachbesserungspflichten, Verletzung eines selbständigen Auskunfts-, Beratungs- oder Garantievertrages sowie aus unerlaubter Handlung. Eine Haftung, aus welchem Rechtsgrund auch immer, über die gesetzlichen Gewährleistungsfristen hinaus ist ausgeschlossen, soweit nicht eine gesonderte Garantie erteilt wurde.

In jedem Falle sind Ersatzleistungen je Schadensereignis auf folgende Höchstbeträge begrenzt:

für Personenschäden	€ 500.000,00
höchstens jedoch	€ 250.000,00
für die einzelnen Personen	
für Sachschäden	€ 50.000,00

Sollten höhere Haftungssummen gewünscht werden, ist dies seitens des Kunden schriftlich mitzuteilen. Die Mehrkosten für eine Erweiterung des Versicherungsumfangs trägt in diesem Fall der Kunde. Für von uns gelieferte fremde Erzeugnisse haften wir grundsätzlich nur in dem Umfang, in dem unsere Vorlieferanten Gewähr für ihre Fabrikate uns gegenüber übernehmen und erfüllen.

9. Eine von uns verkaufte und ordnungsgemäß gelieferte Ware wird grundsätzlich nicht zurückgenommen. Ausnahmen können nur in besonderen Fällen nach vorausgegangener Absprache gemacht werden. Wenn wir uns aus Gründen der Kulanz zu einer Warenrücknahme bereit erklären, werden dem Käufer 10% Verwaltungs-

V AGB

kosten sowie die Transportkosten vom Gutschriftsbetrag in Abzug gebracht. Die Gutschrift erfolgt auf das jeweilige Kundenkonto, wird nicht in bar ausgezahlt und mit weiteren Rechnungen verrechnet. Die Ware muss gut verpackt an uns kostenfrei zurückgeliefert werden. Nacharbeiten, welche durch mangelhafte Verpackung oder andere Einflüsse erforderlich werden, kommen zum Selbstkostenpreis in Anrechnung. Für Sonderausführungen, welche nicht anderweitig weiterverkauft werden können, ist eine Rücknahme ausgeschlossen. Ist als Vergütung der Leistung ein Festpreis vereinbart, so ist überliefertes und nicht benötigtes Material an uns unverzüglich zurückzuliefern. Es erfolgt dafür keine gesonderte Gutschrift an den Kunden. Der Kunde unterliegt der Sorgfaltspflicht zum Umgang der Ware, die evtl. an uns zurückgegeben werden wird, und haftet für Schäden und Folgeschäden an der Ware durch Ausfall, Verlust, mutwillige Beschädigung und Diebstahl.

10. Mietet der Kunde von uns Maschinen oder Arbeitsgeräte, gelten die nachfolgenden Bedingungen:

Bei Versand des Arbeitsgerätes an den Kunden wird in unserem Haus ein Ausgangsprotokoll erstellt. Das bescheinigt die volle Funktionsfähigkeit und den einwandfreien Zustand des Arbeitsgerätes. Mietzeit und Mietzins werden mit dem entsprechenden Vertrag mit dem Kunden schriftlich vereinbart. Der Mietzins ist für die tatsächliche Mietdauer (in Kalendertagen) fällig.

Mietzins

Spiegelschweißmaschine	85 €/Kalendertag
Muffenschweißgerät	45 €/Kalendertag
Schälgerät	45 €/Kalendertag
jeweils zzgl. gültiger, gesetzlicher Mehrwertsteuer	

Der Mietzins versteht sich ohne Verlade- und Frachtkosten. Diese trägt der Kunde.

Ist der Kunde mit der Zahlung eines fälligen Betrages im Rückstand, so sind wir berechtigt, das Gerät auf Kosten des Kunden, der den Zutritt zu den Arbeitsgeräten zu ermöglichen hat, abzuholen und darüber zu verfügen. Die Abholung gilt als fristlose Kündigung des Vertrages.

Der Kunde ist verpflichtet, die Gebrauchsanweisung des Arbeitsgerätes zu beachten, das Gerät an uns in dem Zustand zurückzuliefern, der dem Zustand des Gerätes am Beginn der Mietzeit unter Berücksichtigung der durch den vertragsgemäßen Mietgebrauch entstandenen Wertminderung entspricht und notwendige Reparaturen sofort dem Vermieter zu melden. Der Kunde ist nicht berechtigt, Veränderungen des Arbeitsgerätes vorzunehmen sowie Kennzeichnungen, die von uns angebracht wurden, zu entfernen. Der Kunde darf einem Dritten keine Rechte (z. B. Miete, Leihe) an dem Gerät einräumen, noch Rechte aus dem Vertrag abtreten.

Die überlassenen Arbeitsgeräte sind vom Kunden gegen Diebstahl, Transport- und Montageschäden u. ä. zu versichern.

Der Kunde hat das Gerät in betriebsbereitem Zustand an unser Lager, Anschrift: Spannstiftstraße 37, 58119 Hagen, am Tag nach Ende der Mietzeit zurückzuliefern. Bei Eintreffen des Arbeitsgerätes wird in unserem Haus ein Eingangsprotokoll erstellt, in dem der Stand der Funktionsfähigkeit, der allgemeine Zustand sowie etwaige Defekte oder Mängel festgehalten werden. Wird das Gerät in

einem Zustand zurückgeliefert, der ergibt, dass der Kunde seinen festgelegten Pflichten nicht nachgekommen ist, so hat der Kunde sich für den Zeitraum, der zur Durchführung der deshalb notwendigen Reparatur erforderlich ist, so behandeln zu lassen, als habe er das Gerät nach Ende der Mietzeit weiter behalten. Die erforderlichen Reparaturen werden von uns oder von einem beauftragten Unternehmen ausgeführt. Die Kosten der Reparatur trägt der Kunde. Stellen die Beeinträchtigungen und Beschädigungen des Arbeitsgerätes einen wirtschaftlichen Totalschaden dar, trägt der Kunde die Kosten für die Neuanschaffung eines typgleichen Arbeitsgerätes. Sollte aufgrund von starker Verschmutzung eine Sonderreinigung des Arbeitsgerätes notwendig sein, wird diese mit 50 € pauschal an den Kunden berechnet. Sendet der Kunde das Arbeitsgerät nicht fristgerecht am Ende Mietzeit an uns zurück, wird der reguläre Mietzins pro weiteren Kalendertag an den Kunden berechnet.

Wir sind jederzeit berechtigt, das Arbeitsgerät zu besichtigen oder durch einen Beauftragten besichtigen zu lassen. Der Kunde ist verpflichtet, dem Vermieter die Untersuchung in jeder Weise zu erleichtern. Die Gefahren des Untergangs, Verlustes oder Diebstahls, ausbesserungsfähiger und nicht ausbesserungsfähiger Beschädigungen sowie des vorzeitigen Verschleißes des Mietgegenstandes trägt der Kunde, auch wenn ihn kein Verschulden trifft. Die Gefahrtragung des Kunden beginnt mit der Übergabe des Gerätes an ihn oder den Frachtführer und endet bei Rücklieferung mit Übergabe an uns. Der Kunde trägt die Haftpflichtansprüche Dritter während der Zeit, in der er das Gerät in seiner Verfügungsgewalt hat.

Der durch den Vertrag und die Überlassung der Arbeitsgeräte an den Kunden rechtsverbindlich geschlossene Mietvertrag kann von beiden Parteien mit einer Frist von einer Woche zum Wochenende schriftlich gekündigt werden. Der Mietvertrag kann nur von uns ohne Einhaltung einer Frist gekündigt werden, wenn der Kunde ohne unsere Einwilligung das Gerät vertragswidrig nutzt, wenn der Kunde einem Dritten das Gerät weitervermietet oder Rechte aus diesem Vertrag abtritt oder Rechte an dem Gerät einräumt, wenn bei einer Untersuchung festgestellt wird, dass das Gerät durch fortgesetzte Vernachlässigung der dem Kunden obliegenden Sorgfaltspflichten erheblich gefährdet ist oder wenn der Kunde mit der Mietzinszahlung in Verzug kommt.

11. Sämtliche dem Kunden zur Verfügung gestellten Unterlagen und Informationen über Produktspezifikation, insbesondere Isometrien, Materialauszüge, Berechnungsstatistiken und Revisionsunterlagen dienen allein der unverbindlichen allgemeinen Information des Kunden. Technische Auslegungen auf Basis der vorgenannten Unterlagen und Informationen erfolgen grundsätzlich nach dem aktuellen, uns vorliegenden Planstand. Für die inhaltliche Richtigkeit und Vollständigkeit dieser dem Kunden zur Verfügung gestellten Unterlagen sowie jedwede weitere unentgeltliche Leistung gegenüber dem Kunden wird eine Haftung nicht begründet. Im Übrigen gelten die Regelungen zu Ziffer 8.

An allen im Zusammenhang mit der Auftragserteilung dem Kunden überlassenen Unterlagen behalten wir uns Eigentums- und Urheberrechte vor. Diese Unterlagen dürfen Dritten nicht zugänglich gemacht werden, es sei denn,

V AGB

wir erteilen dem Kunden unsere ausdrückliche schriftliche Zustimmung.

12. Erfüllungsort für unsere Lieferungen ist der jeweils auf dem Lieferschein angegebene Versandort, nach unserer Wahl auch Castrop-Rauxel. Erfüllungsort für die Zahlungsverpflichtung des Bestellers sowie Gerichtsstand ist Castrop-Rauxel. Wir behalten uns jedoch das Recht vor, zum gerichtlichen Einzug unserer Forderungen am Hauptsitz des Bestellers zu klagen. Bei Auslandslieferungen ist deutsches Recht maßgebend. Technische-, Sortiments- und Preisänderungen sind vorbehalten. Die Haftung für Druckfehler und -mängel wird ausgeschlossen.

13. Sind die vorstehenden AGB ganz oder teilweise nicht Vertragsbestandteil geworden oder unwirksam, so bleibt der Vertrag im Übrigen wirksam. Soweit die Bestimmungen nicht Vertragsbestandteil geworden oder unwirksam geworden sind, gelten die gesetzlichen Vorschriften.

Stand: 01.01.2013

Sicher Entwässern mit System -

mit Siaqua Flachdachentwässerung von Sikla Drain!



Sikla Drain GmbH
Erinstraße 14
44575 Castrop-Rauxel
Tel.: 02305 9778 0
Fax.: 02305 9778 13
Email: info@sikladrain.com
www.sikladrain.com